



INSTALLATION INSTRUCTIONS



2011 - 2015 FORD F-250 6.2L

PART NO. 19174

BILL OF MATERIALS:

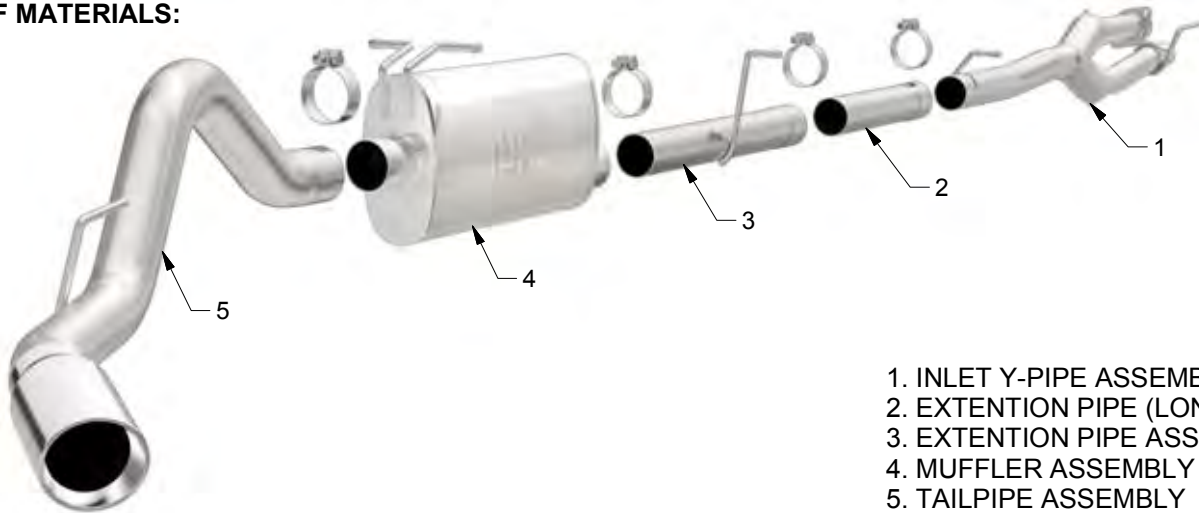

- 1. INLET Y-PIPE ASSEMBLY
- 2. EXTENSION PIPE (LONG BED)
- 3. EXTENSION PIPE ASSEMBLY
- 4. MUFFLER ASSEMBLY
- 5. TAILPIPE ASSEMBLY



WEAR SAFETY GLASSES



READ INSTRUCTIONS THOROUGHLY BEFORE INSTALLING PRODUCT



SPRAY LUBRICANT

To ease removal of existing exhaust components (especially on older vehicles) spray penetrating lubricant on all fasteners and hangers/insulators that will be loosened or removed and let soak before disassembly.

HARDWARE KIT:

1.[4] 3.50" Clamp

MINIMUM REQUIRED TOOLS:



15mm



Hanger Tool (Or Pry Bar)

MAGNAFLOW RECOMMENDS PROFESSIONAL INSTALLATION ON ALL THEIR PRODUCTS



WARNING: When working on, under, or around any vehicle exercise caution. Please allow the vehicle's exhaust system to cool before removal, as exhaust system temperatures may cause severe burns. If working without a lift always consult vehicle manual for correct lifting specifications. Always wear safety glasses and ensure a safe work area. Serious injury or death could occur if safety measures are not followed.

ATTENTION: Always install any supplied band or U-bolt clamps to the proper torque specifications of 40-45 ft-lbs for band clamps and 30-35 ft-lbs for U-bolt clamps. Over tightening will result in the clamp breaking and will NOT be warranted by MagnaFlow.

INSTALLATION INSTRUCTIONS



Step 1. To remove the OEM exhaust system, unbolt the flange and clamp attaching the systems inlet pipes to the catalytic converter outlet pipes. Disengage all welded hangers from the OEM rubber insulators. Do not discard the OEM fasteners or damage the rubber insulators as they will be needed to mount your new MAGNAFLOW system.



Step 2. Install the new system by attaching the Inlet Y-Pipe Assembly to the OEM catalytic converter outlet pipes using the existing clamp and hardware. Locate the welded hanger to the rubber insulator. Leave all clamps and fasteners loose for final adjustment of the complete system once installed.



Step 3. Install the Mid Pipe Extension Assembly using the supplied 3.50" clamp. Use the supplied 19.25" Extension Pipe between the Inlet Y-Pipe Assembly and the Mid Pipe Extension Assembly if your truck has a long bed configuration.



Step 4. Install both the Muffler Assembly and Tail Pipe Assembly using the supplied 3.50" clamps. Locate the welded hangers to the OEM rubber insulators.





Step 5. Once a final position has been chosen for the new exhaust system, evenly tighten all clamps from front to rear using the torque specifications on page one of the instructions. Inspect all fasteners after 25-50 miles of operation and re-tighten if necessary.