



INSTALLATION INSTRUCTIONS



2015-2018 CHEVY CRUZE 1.4L

PART NO. 19269

BILL OF MATERIALS:

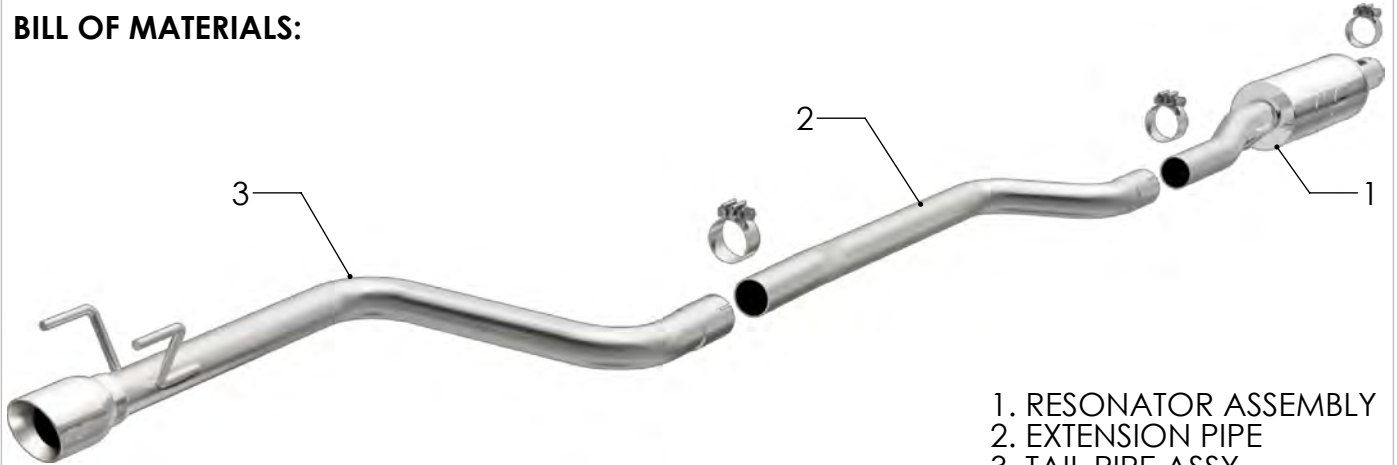

- 1. RESONATOR ASSEMBLY
- 2. EXTENSION PIPE
- 3. TAIL PIPE ASSY.

SHOP SUPPLIES:



WEAR SAFETY GLASSES



READ INSTRUCTIONS THOROUGHLY BEFORE INSTALLING PRODUCT



SPRAY LUBRICANT

To ease removal of existing exhaust components (especially on older vehicles) spray penetrating lubricant on all fasteners and hangers/insulators that will be loosened or removed and let soak before disassembly.

HARDWARE KIT:

- 1. [2] 2.25" Clamp
- 2. [1] 2.38" Clamp

MINIMUM REQUIRED TOOLS:



12, 14, 15 mm



Hanger Tool (Or Pry Bar)

MAGNAFLOW RECOMMENDS PROFESSIONAL INSTALLATION ON ALL THEIR PRODUCTS



WARNING: When working on, under, or around any vehicle exercise caution. Please allow the vehicle's exhaust system to cool before removal, as exhaust system temperatures may cause severe burns. If working without a lift always consult vehicle manual for correct lifting specifications. Always wear safety glasses and ensure a safe work area. Serious injury or death could occur if safety measures are not followed.

ATTENTION: Always install any supplied band or U-bolt clamps to the proper torque specifications of 40-45 ft-lb for band clamps and 30-35 ft-lb for U-bolt clamps. Over tightening will result in the clamps breaking and will NOT be warranted by MagnaFlow.

MAGNAFLOW: 1901 Corporate Centre Dr - Oceanside, CA 92056 | 1(800)990-0905

Technical Support: 1(800) 959-9226 | Email: moreinfo@magnaflow.com

INSTALLATION INSTRUCTIONS



Step 1: To install the MagnaFlow exhaust the OE system must be cut. Measure 3.00" back from the catalytic converter weld, cut at this point and deburr pipe. Working front to rear disengage all welded hangers from the rubber insulators. The OEM exhaust system can now be removed in one piece. Be sure to retain the rubber hanger insulators as they will be needed to install your new MagnaFlow system.



Step 2: Begin installing your new system by sliding the Resonator Assembly over the cut pipe and loosely attaching with the provided 2.38" clamp. Engage the hanger to the rubber insulator.



Step 3: Next loosely fasten the Extension Pipe to the Resonator Assembly using the supplied 2.25" clamp. Then attach Tail Pipe Assembly in a similar fashion engaging the welded hangers to the rubber insulators.



Step 4: Once a final position has been chosen for the new exhaust system, evenly tighten all clamps from front to rear using the torque specifications on page one of these instructions. Inspect all fasteners after 25-50 miles for operation and re-tighten if necessary.