



INSTALLATION INSTRUCTIONS



2014 MAZDA 3 2.0L SEDAN | PART NO. 15294

BILL OF MATERIALS:

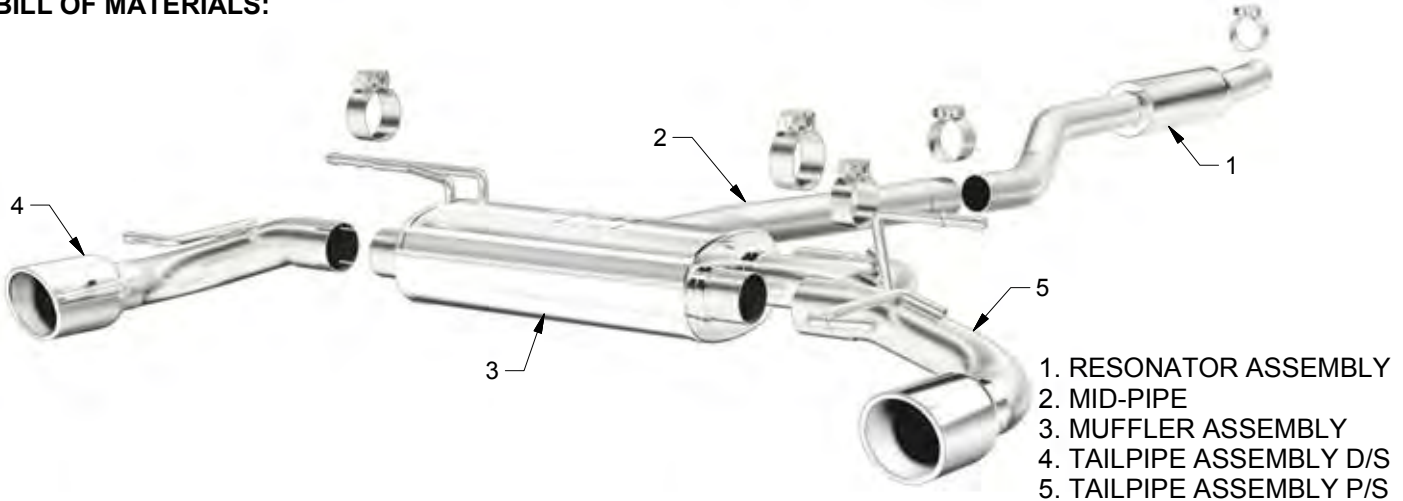

WEAR SAFETY GLASSES



READ INSTRUCTIONS THOROUGHLY BEFORE INSTALLING PRODUCT

SHOP SUPPLIES:



SPRAY LUBRICANT

To ease removal of existing exhaust components (especially on older vehicles) spray penetrating lubricant on all fasteners and hangers/insulators that will be loosened or removed and let soak before disassembly.

HARDWARE KIT:

1.[5] 2.50" Clamp

MINIMUM REQUIRED TOOLS:



15mm
12mm



Hanger Tool
(Or Pry Bar)



Sawzall (Or other cutting device)

MAGNAFLOW RECOMMENDS PROFESSIONAL INSTALLATION ON ALL THEIR PRODUCTS



WARNING: When working on, under, or around any vehicle exercise caution. Please allow the vehicle's exhaust system to cool before removal, as exhaust system temperatures may cause severe burns. If working without a lift always consult vehicle manual for correct lifting specifications. Always wear safety glasses and ensure a safe work area. Serious injury or death could occur if safety measures are not followed.

ATTENTION: Always install any supplied band or U-bolt clamps to the proper torque specifications of 40-45 ft-lbs for band clamps and 30-35 ft-lbs for U-bolt clamps. Over tightening will result in the clamp breaking and will NOT be warranted by MagnaFlow.

X INSTALLATION INSTRUCTIONS

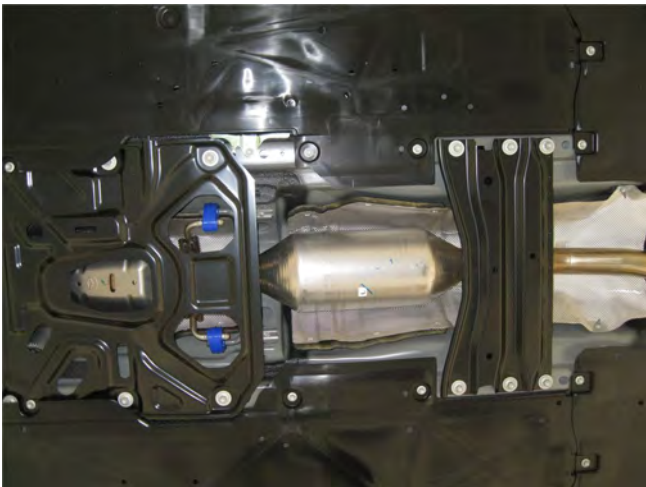

Step 1. Removal of this exhaust system requires cutting and de-burring the pipe 2.50" behind the hanger assembly welded to the pipe behind the catalytic converter. To accomplish this you must remove the cross brace and catalytic converter shield.



Step 2. Unfasten the flange at the rear muffler junction, disengage rubber insulators (Do not damage insulators as they will be used in the new installation).



Step 3. Begin installation of your new MAGNAFLOW system by attaching the Resonator Assembly to the cut outlet behind the catalytic converter using the supplied 2.50" clamp. Keep all fasteners and clamps loose until final adjustment.

X INSTALLATION INSTRUCTIONS



Step 4. Next use the supplied 2.50" clamps to attach the Mid-Pipe to the Resonator Assembly and the Muffler Assembly to the Mid Pipe. Insert hangers into rubber insulators.



Step 5. Finish by attaching the Tail Pipe Assemblies to the Muffler with the supplied 2.50" clamps and fit hangers into rubber insulators.



Step 6. Once a final position has been chosen for the new exhaust system, evenly tighten all clamps from front to rear using the torque specifications on page one of the instructions. Inspect all fasteners after 25-50 miles of operation and re-tighten if necessary.