



INSTALLATION INSTRUCTIONS



'14-'15 CHEVY SILVERADO 1500/GMC SIERRA 1500 4.3L/5.3L | PART NO. 15278

BILL OF MATERIALS:

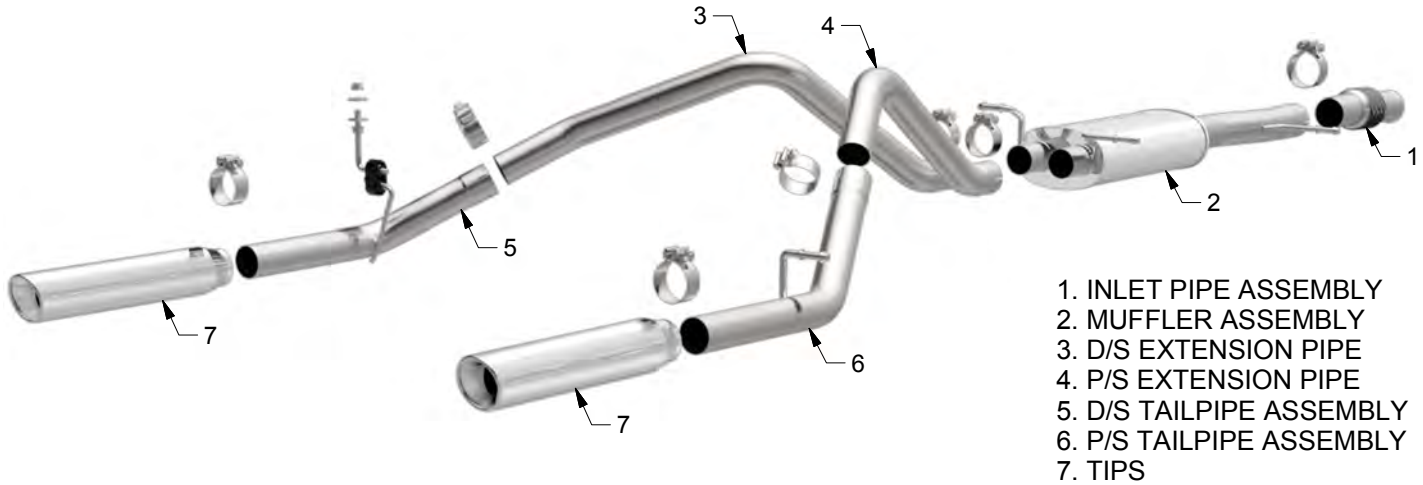

WEAR SAFETY GLASSES



READ INSTRUCTIONS THOROUGHLY BEFORE INSTALLING PRODUCT

SHOP SUPPLIES:



SPRAY LUBRICANT

To ease removal of existing exhaust components (especially on older vehicles) spray penetrating lubricant on all fasteners and hangers/insulators that will be loosened or removed and let soak before disassembly.

HARDWARE KIT:

- 1.[6] 2.50" Clamp
- 2.[1] 3.00" Clamp
- 3.[1] Rubber Insulator
- 4.[1] Hanger, Threaded
- 5.[2] Nut 7/16-14
- 6.[2] Washer

MINIMUM REQUIRED TOOLS:



13mm
15mm



Hanger Tool
(Or Pry Bar)



Sawzall or other cutting device.

MAGNAFLOW RECOMMENDS PROFESSIONAL INSTALLATION ON ALL THEIR PRODUCTS



WARNING: When working on, under, or around any vehicle exercise caution. Please allow the vehicle's exhaust system to cool before removal, as exhaust system temperatures may cause severe burns. If working without a lift always consult vehicle manual for correct lifting specifications. Always wear safety glasses and ensure a safe work area. Serious injury or death could occur if safety measures are not followed.

ATTENTION: Always install any supplied band or U-bolt clamps to the proper torque specifications of 40-45 ft-lbs for band clamps and 30-35 ft-lbs for U-bolt clamps. Over tightening will result in the clamp breaking and will NOT be warranted by MagnaFlow.

INSTALLATION INSTRUCTIONS



Step 1. To remove the OEM exhaust system, you will first need to cut the pipe behind the muffler before it goes over the axle. You can then disengage the welded hangers from the rubber insulators and remove the tailpipe. Unfasten the muffler inlet from the catalytic converter at the clamp junction. Do not damage or discard the OEM fasteners or rubber insulators, as they will be reused to mount the new system. Disengage the muffler hangers and remove it from the vehicle.



Step 2. Before installing your new system, to convert the vehicle to dual tips you must install the supplied threaded hanger into the driver side frame rail with the supplied fasteners as shown.



Step 3. Install the new Inlet Pipe Assembly at the ball flare using the OEM clamp. Leave all clamps and fasteners loose for final adjustment of the complete system.



Step 4. Working front to rear install the remaining pieces of the MAGNAFLOW system, inserting hangers into rubber insulators and loosely installing supplied clamps. Adjustable tips are supplied to fit a variety of aftermarket bumpers and rollpans, once a position is decided for the tips it is recommended to have them welded into place.



Step 5. Once a final position has been chosen for the new exhaust system, evenly tighten all clamps from front to rear using the torque specifications on page one of the instructions. Inspect all fasteners after 25-50 miles of operation and re-tighten if necessary.