



INSTALLATION INSTRUCTIONS



CANYON | COLORADO 2.7L | PART NO. 19650

BILL OF MATERIALS:

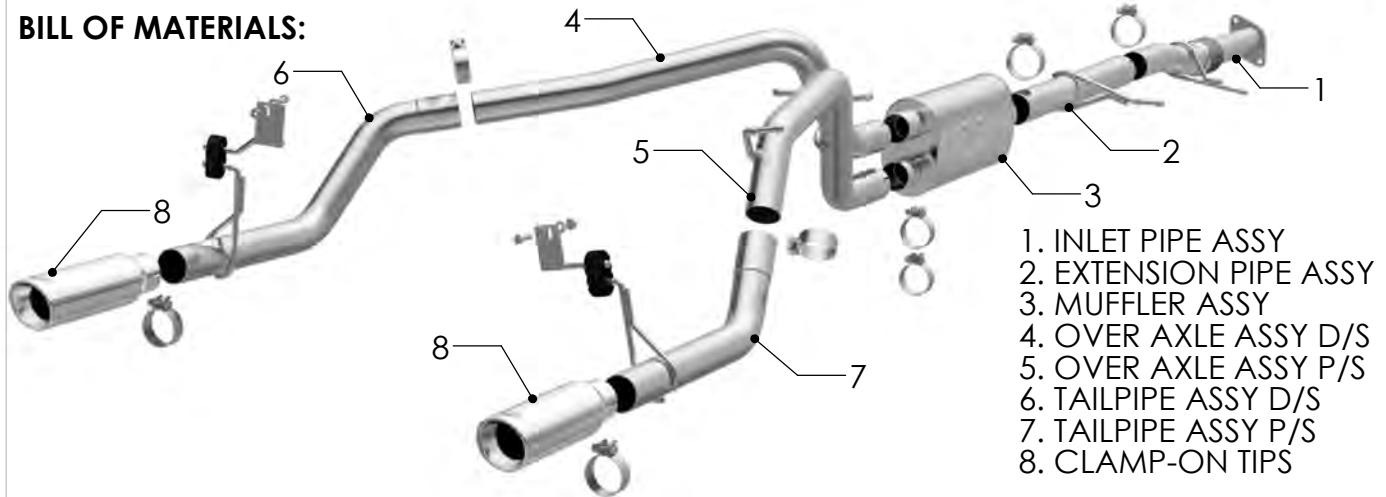

WEAR SAFETY GLASSES



READ INSTRUCTIONS THOROUGHLY BEFORE INSTALLING PRODUCT



SPRAY LUBRICANT

To ease removal of existing exhaust components (especially on older vehicles) spray penetrating lubricant on all fasteners and hangers/insulators that will be loosened or removed and let soak before disassembly.

HARDWARE KIT:

1. [3] 3.00" Torca Clamp
2. [6] 2.50" Torca Clamp
3. [1] Hanger Bkt Assy D/S
4. [1] Hanger Bkt Assy P/S
5. [2] Rubber Insulator
6. [2] Bolt 3/8-16 x 1.00"
7. [2] Stover Nut 3/8-16
8. [4] Washer 3/8 Zinc
9. [2] 8" Zip Tie

MINIMUM REQUIRED TOOLS:



13mm



Hanger Tool (Or Pry Bar)

MAGNAFLOW RECOMMENDS PROFESSIONAL INSTALLATION ON ALL THEIR PRODUCTS



WARNING: When working on, under, or around any vehicle exercise caution. Please allow the vehicle's exhaust system to cool before removal, as exhaust system temperatures may cause severe burns. If working without a lift always consult vehicle manual for correct lifting specifications. Always wear safety glasses and ensure a safe work area. Serious injury or death could occur if safety measures are not followed.

ATTENTION: Always install any supplied band or U-bolt clamps to the proper torque specifications of 40-45 ft-lb for band clamps and 30-35 ft-lb for U-bolt clamps. Over tightening will result in the clamps breaking and will NOT be warranted by MagnaFlow.

MAGNAFLOW: 1901 Corporate Centre Dr - Oceanside, CA 92056 | 1(800)990-0905
 Technical Support: 1(800) 959-9226 | Email: moreinfo@magnaflow.com

INSTALLATION INSTRUCTIONS



Step 1: Begin extracting the OE exhaust by removing the fasteners at the two bolt flange junction. Retain these fasteners to use on the new exhaust installation,



Step 2: Working front to rear, disengage all welded hangers from the rubber insulators and remove the system. (Retain the rubber insulators as they will be needed to mount the new MAGNAFLOW system.)

Step 3: You will also need to remove the spare wheel and heat shields permanently.



Step 4: Begin Installing the new MagnaFlow exhaust system by attaching the inlet pipe to the flange outlet using the OE fasteners.



Step 5: Next attach the Extension pipe to the Inlet Assembly using a supplied 3.00" Clamp, fit the hanger into the rubber insulator. Next attach the Oval Muffler to the Extension Pipe with the supplied 3.00" clamp,

INSTALLATION INSTRUCTIONS



Step 6: Install the Over Axle Pipes to the Muffler outlets using the supplied clamps. Engage all hangers into the rubber insulators.



Step 7: To enable the conversion to a dual outlet system supplied hanger brackets must be installed to the frame, the hanger with bends is installed on the Drivers Side and the straight hanger on the Passenger Side. Use the supplied fasteners to mount the hanger brackets as shown.



Step 8: Loosely install the Tailpipe Assemblies to the Over Axle pipes using the supplied 2.50" clamps and by fitting the hangers into the supplied Rubber Insulators attached to the Hanger Brackets.

INSTALLATION INSTRUCTIONS



Image A

Step 9: Install the two Clamp-On Tips using the supplied 2.50" clamps at desired location. At this point use the supplied Zip Tie to bind the fuel lines up and away from the exhaust. (see Image A and B)



Image B



Step 10: Once a final position has been chosen for the new exhaust system, evenly tighten all clamps from front to rear using the torque specifications on page one of the instructions. Inspect all fasteners after 25-50 miles of operation and re-tighten if necessary.