

1964 - '72 GM A-BODY

Buick GS & Skylark, Chevrolet Chevelle Malibu & El Camino, Oldsmobile Cutlas & 442, Pontiac Judge & GTO

Note: This system is designed to work with OEM-style exhaust manifolds, or tubular headers. Due to the various applications possible, some modification and welding is required for a proper fit and finish.

Warning: When working on, under, or around any vehicle exercise caution. Please allow the vehicle's exhaust system to cool before removal, as exhaust system temperatures may cause severe burns. If working without a lift, always consult vehicle manual for correct lifting specifications. Always wear safety glasses and ensure a safe work area. Serious injury or death could occur if safety measures are not followed.

Step 1: (Carefully read all instructions before installation)

Disconnect the battery before removal of the existing exhaust system. Remove the existing exhaust system from the exhaust manifolds / headers. Some systems may need to be cut for removal. Take notice of axle position and brake line position.

Step 2: Remove OEM muffler body hangers, using a 1/2" drill bit. Enlarge the holes as shown in diagram B. Using the supplied nuts, place the hanger in the hole and snug the nuts in place as shown in diagram C. Install the supplied rubber insulators and hang the mufflers in place.

Step 3: While the mufflers are hanging, install the tru-x scavenger pipe assembly. Be sure to orient the pipe to allow for drive shaft travel and to sit below e-brake cables. Using the supplied band clamps, snug the mufflers to the X and position the front inlet pipe extensions.

Step 4: Inlet pipe extensions can be cut on both ends to accommodate different header and manifold spreads, as shown in diagram D. From these pipes, header connectors flanges can be welded or custom manifold down pipes can be attached.

Step 5: For pre axle turn down tips may be installed on the muffler, Skip to step 7. If after axle tailpipes are desired, continue to step 6.

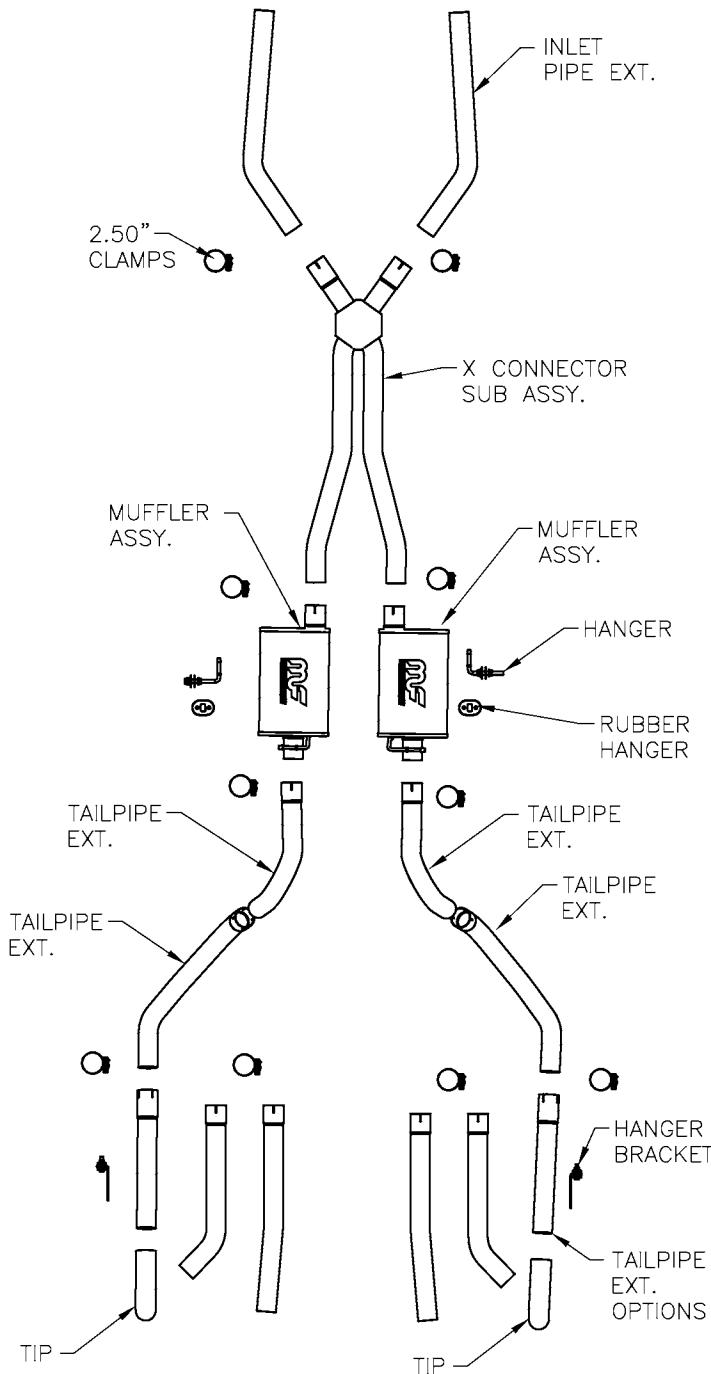

*MAGNAFLOW Performance Exhaust recommends professional installation on all their products

Technical support: 1-800-959-9226 ext. 4500

1964-'72 GM A-BODY

Buick GS & Skylark, Chevrolet Chevelle Malibu & WI Camino, Oldsmobile Cutlas & 442, Pontiac Judge & GTO



Diagram "B"



Diagram "C"

Note: This system is designed to work with OEM-style exhaust manifolds, or tubular headers. Due to the various applications possible, some modification and welding is required for a proper fit and finish.

Warning: When working on, under, or around any vehicle exercise caution. Please allow the vehicle's exhaust system to cool before removal, as exhaust system temperatures may cause severe burns. If working without a lift, always consult vehicle manual for correct lifting specifications. Always wear safety glasses and ensure a safe work area. Serious injury or death could occur if safety measures are not followed.

Step 6: Install the over axle pipes into place and snug them into place with supplied band clamps. Next install your choice of tailpipe exits and tighten them into place. For under bumper pipes, we have provided an additional set of hanger brackets which can be bolted to the frame as in diagram E then bent as needed and weld to the tail pipe.

Step 7: Once a final position has been chosen for the new system, evenly tighten all fasteners from front to rear. Inspect all fasteners after 25-50 miles of operation and retighten if necessary.

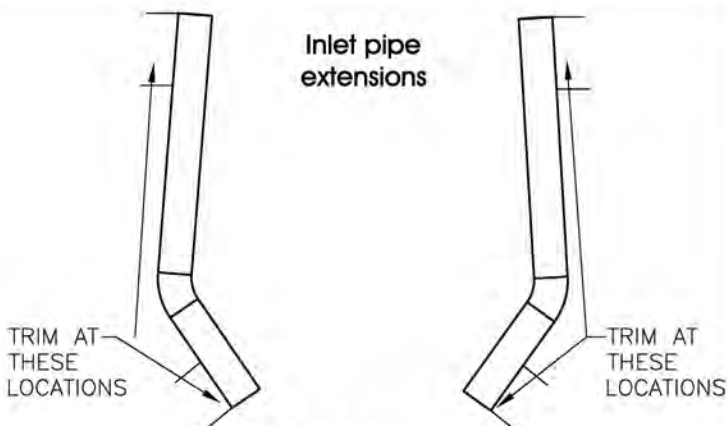

Diagram "D"

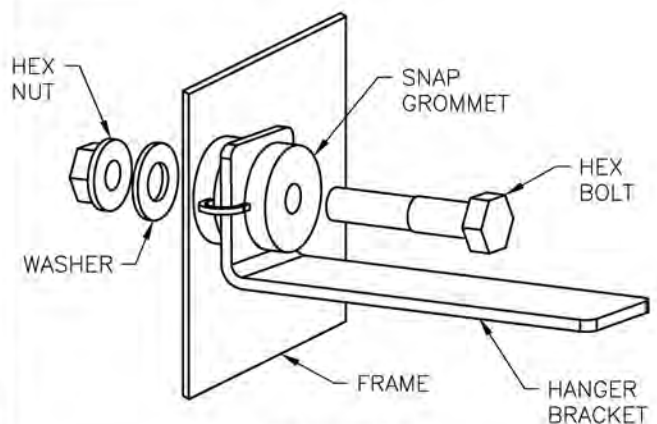

Diagram "E"

*MAGNAFLOW Performance Exhaust recommends professional installation on all their products

Technical support: 1-800-959-9226 ext. 4500

MAGNAFLOW Performance Exhaust - 22961 Arroyo Vista - Rancho Santa Margarita, CA 92688

15893/ 15894 11/29/04 R001