



INSTALLATION INSTRUCTIONS



2015 KIA OPTIMA 2.0/2.4L | PART NO. 19237

BILL OF MATERIALS:

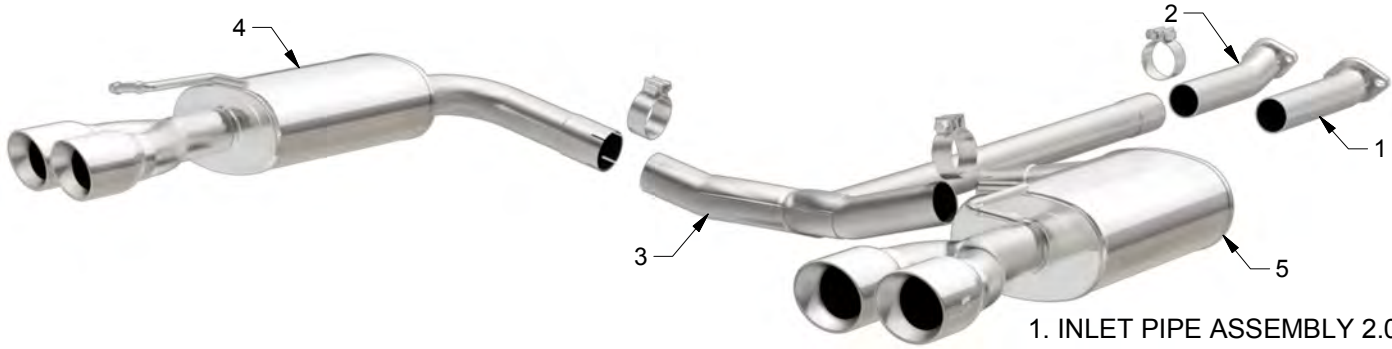

- 1. INLET PIPE ASSEMBLY 2.0L
- 2. INLET PIPE ASSEMBLY 2.4L
- 3. Y-PIPE ASSEMBLY
- 4. MUFFLER ASSEMBLY D/S
- 5. MUFFLER ASSEMBLY P/S



WEAR SAFETY GLASSES



READ INSTRUCTIONS THOROUGHLY BEFORE INSTALLING PRODUCT

SHOP SUPPLIES:



SPRAY LUBRICANT

To ease removal of existing exhaust components (especially on older vehicles) spray penetrating lubricant on all fasteners and hangers/insulators that will be loosened or removed and let soak before disassembly.

HARDWARE KIT:

- 1.[3] 2.50" Clamp

MINIMUM REQUIRED TOOLS:



15mm, 19mm



Hanger Tool (Or Pry Bar)

MAGNAFLOW RECOMMENDS PROFESSIONAL INSTALLATION ON ALL THEIR PRODUCTS



WARNING: When working on, under, or around any vehicle exercise caution. Please allow the vehicle's exhaust system to cool before removal, as exhaust system temperatures may cause severe burns. If working without a lift always consult vehicle manual for correct lifting specifications. Always wear safety glasses and ensure a safe work area. Serious injury or death could occur if safety measures are not followed.

ATTENTION: Always install any supplied band or U-bolt clamps to the proper torque specifications of 40-45 ft-lbs for band clamps and 30-35 ft-lbs for U-bolt clamps. Over tightening will result in the clamp breaking and will NOT be warranted by MagnaFlow.



Step 1. To extract the OEM exhaust system begin by un-fastening the flange located behind the resonator and the second flange located in front of the Driver side muffler assembly. Next, working rearward, disengage all welded hangers from the rubber insulators. Do not damage or discard the rubber insulators or fasteners as they will be re-used to mount the new system. You can now remove the exhaust from the vehicle.

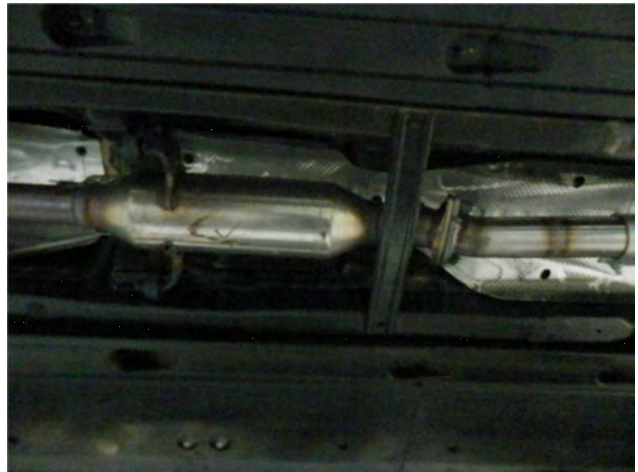

Step 2. This Magnaflow exhaust system will fit both a 2.0L Turbo and a NA 2.4L Optima depending on which Inlet pipe Assembly is used (both are supplied). The 2.0L Turbo Inlet Pipe has the slotted flange. Begin installation of the new system by fastening the correct Inlet Assembly to the resonator outlet using the OEM fasteners (Leave all clamps and fasteners loose for final adjustment of the complete system.)



Step 3. Next Install the Y-Pipe Assembly to the Inlet Pipe Assembly using the supplied 2.50" clamp. Insert hanger into rubber insulator.



Step 4. Finish by Installing the Muffler Assemblies to the outlets of the Resonator Assembly using the supplied 2.50" clamps. Insert hangers into rubber insulators. .



Step 5. Once a final position has been chosen for the new exhaust system, evenly tighten all clamps from front to rear using the torque specifications on page one of the instructions. Inspect all fasteners after 25-50 miles of operation and re-tighten if necessary.