



INSTALLATION INSTRUCTIONS



SYSTEM COMPETITION CAT-BACK CHEVROLET | PART NO. 19265

BILL OF MATERIALS:

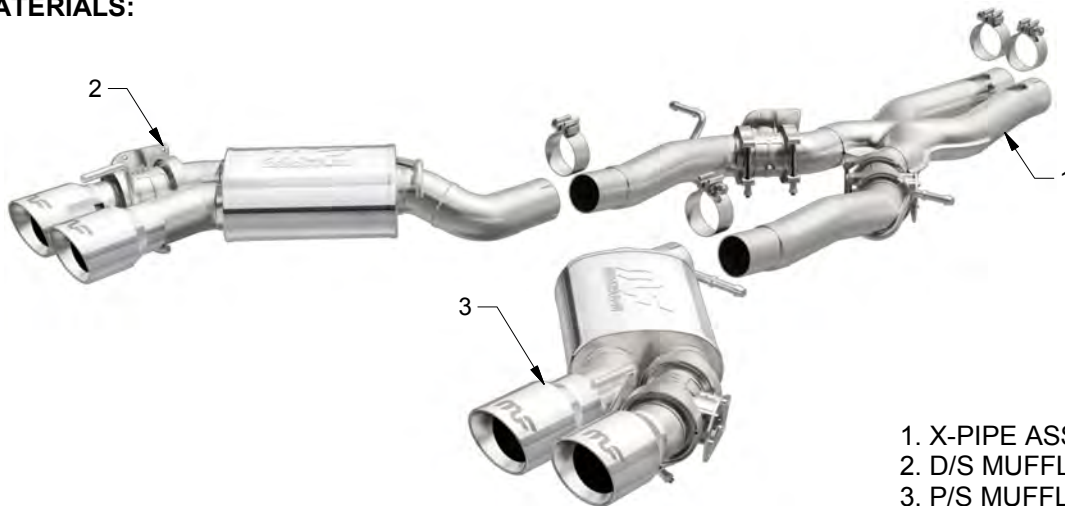

- 1. X-PIPE ASSEMBLY
- 2. D/S MUFFLER ASSEMBLY
- 3. P/S MUFFLER ASSEMBLY



WEAR SAFETY GLASSES



READ INSTRUCTIONS THOROUGHLY BEFORE INSTALLING PRODUCT

SHOP SUPPLIES:



SPRAY LUBRICANT

To ease removal of existing exhaust components (especially on older vehicles) spray penetrating lubricant on all fasteners and hangers/insulators that will be loosened or removed and let soak before disassembly.

HARDWARE KIT:

- 1. [4] 2.75" Clamp
- 2. [6] Zip Ties

MINIMUM REQUIRED TOOLS:



8mm, 15mm



Hanger Tool (Or Pry Bar)



Phillips, Flat Head



Sawzall or similar cutting device

MAGNAFLOW RECOMMENDS PROFESSIONAL INSTALLATION ON ALL THEIR PRODUCTS



WARNING: When working on, under, or around any vehicle exercise caution. Please allow the vehicle's exhaust system to cool before removal, as exhaust system temperatures may cause severe burns. If working without a lift always consult vehicle manual for correct lifting specifications. Always wear safety glasses and ensure a safe work area. Serious injury or death could occur if safety measures are not followed.

ATTENTION: Always install any supplied band or V-band clamps to the proper torque specifications of 40-45 ft-lbs for band clamps and 70 in-lbs for V-band clamps. Over tightening will result in the clamp breaking and will NOT be warranted by MagnaFlow.

X INSTALLATION INSTRUCTIONS

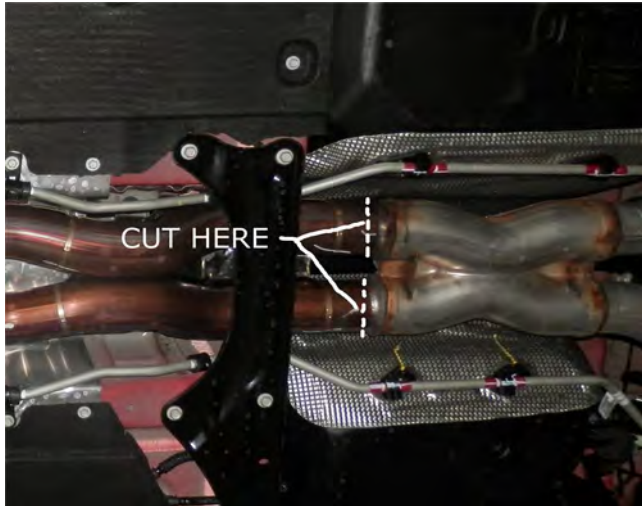

Step 1. It is necessary to cut the factory exhaust system to install the new Magnaflow unit. To do this cut the band clamps holding the heat shield to the pipes in front of the X. Move the heatshield out of the way and cut 1/2" in front of the welds on the factory X-Pipe. Deburr the cut pipes to facilitate installation of the new system.



Step 2. Next you will need to unplug the electrical connection on the Exhaust Valve Control Motors (Qty 4) located on the OEM exhaust assembly.



Step 3. Working front to rear disengage all welded hangers from the rubber insulators and remove the system. (Retain the insulators as they will be needed to mount the new MAGNAFLOW system.) Once the OEM system is on the ground transfer all the valve motors over to the new Magnaflow exhaust system.



Step 4. Begin installation of the new system by sliding the X-Pipe Assembly inlets onto the cut outlets of the OEM exhaust and loosely fasten with the supplied 2.75" clamps. (at this time slide the loose end of the cut heatshield under the clamps before tightening). Fit hangers into rubber insulators.

X INSTALLATION INSTRUCTIONS



Step 5. Install the Muffler Assemblies to the X-Pipe Assembly with the supplied 2.75" clamps and engage the welded hangers to the rubber insulators. Leave all clamps loose for final adjustment of the system.



Step 6. To re-connect the wiring harness plugs to the Valve motors you may need to cut their plastic anchors. After having done this attach the plugs to the motors and re-anchor the wires with a supplied Zip Tie.



Step 7. Once a final position has been chosen for the new exhaust system, evenly tighten all clamps from front to rear using the torque specifications on page one of the instructions. Inspect all fasteners after 25-50 miles of operation and re-tighten if necessary.