



# INSTALLATION INSTRUCTIONS



2015 AUDI Q5 3.0L

PART NO. 15378

## BILL OF MATERIALS:

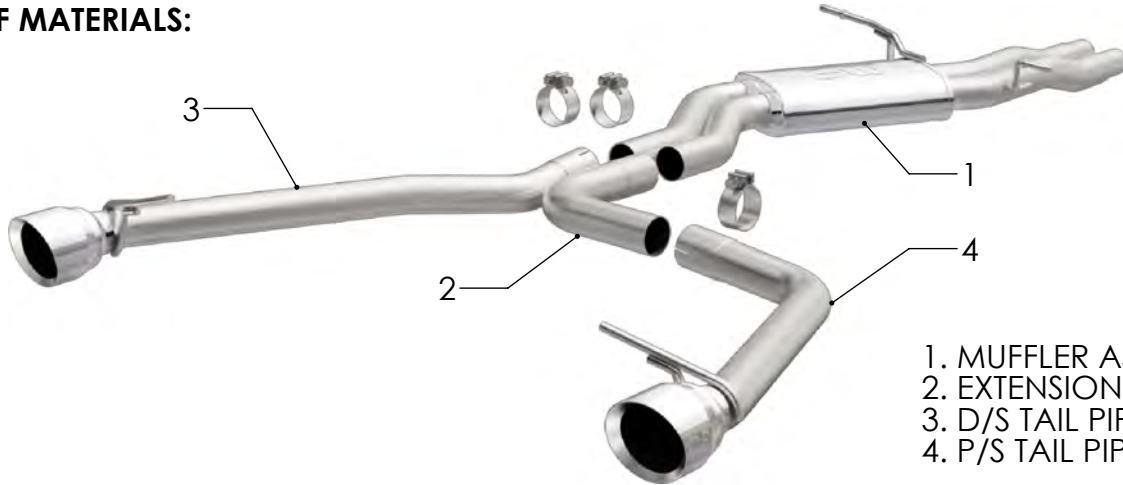

- 1. MUFFLER ASSEMBLY
- 2. EXTENSION PIPE
- 3. D/S TAIL PIPE ASSY.
- 4. P/S TAIL PIPE ASSY.



WEAR SAFETY GLASSES



READ INSTRUCTIONS THOROUGHLY BEFORE INSTALLING PRODUCT



SPRAY LUBRICANT

To ease removal of existing exhaust components (especially on older vehicles) spray penetrating lubricant on all fasteners and hangers/insulators that will be loosened or removed and let soak before disassembly.

## HARDWARE KIT:

- 1. [3] 2.50" Clamp

## MINIMUM REQUIRED TOOLS:



12, 14, 15 mm



Hanger Tool (Or Pry Bar)

## MAGNAFLOW RECOMMENDS PROFESSIONAL INSTALLATION ON ALL THEIR PRODUCTS



**WARNING:** When working on, under, or around any vehicle exercise caution. Please allow the vehicle's exhaust system to cool before removal, as exhaust system temperatures may cause severe burns. If working without a lift always consult vehicle manual for correct lifting specifications. Always wear safety glasses and ensure a safe work area. Serious injury or death could occur if safety measures are not followed.

**ATTENTION:** Always install any supplied band or U-bolt clamps to the proper torque specifications of 40-45 ft-lb for band clamps and 30-35 ft-lb for U-bolt clamps. Over tightening will result in the clamps breaking and will NOT be warranted by MagnaFlow.

MAGNAFLOW: 1901 Corporate Centre Dr - Oceanside, CA 92056 | 1(800)990-0905

Technical Support: 1(800) 959-9226 | Email: [moreinfo@magnaflow.com](mailto:moreinfo@magnaflow.com)

## INSTALLATION INSTRUCTIONS

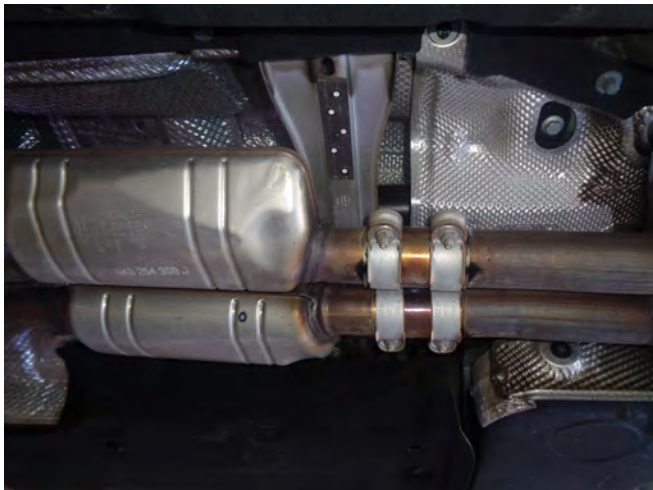

Step 1: To remove the OEM system first loosen both band clamps attaching the exhaust system to the catalytic converter outlet pipes. Working front to rear disengage all welded hangers from the rubber insulators. The OEM exhaust system can now be removed in one piece. Be sure to retain all mounting hardware as it will be needed to install your new MAGNAFLOW system



Step 2: Begin installing your new system by loosely attaching the Muffler Assembly by inserting the two inlet pipes into the OEM band clamps at the catalytic converter outlets. Engage both hangers to the rubber insulators.



Step 3: Next loosely fasten the Extension Pipe to the passengers side outlet pipe of the Muffler Assembly using the supplied clamp. Then attach both Tail Pipe Assemblies in a similar fashion engaging the welded hangers to the rubber insulators.

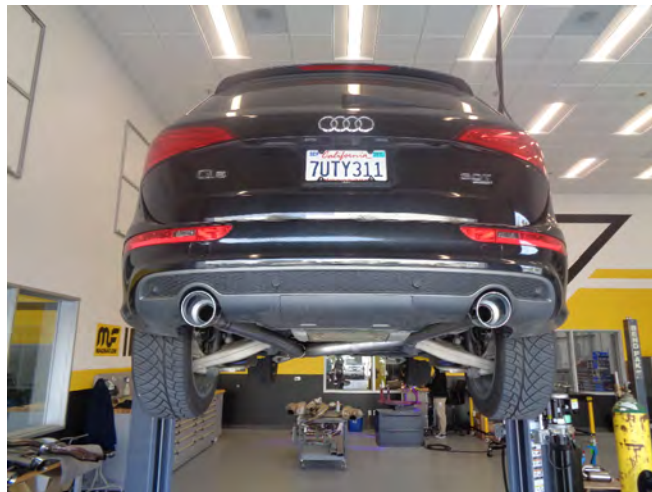

Step 4: Once a final position has been chosen for the new exhaust system, evenly tighten all clamps from front to rear using the torque specifications on page one of these instructions. Inspect all fasteners after 25-50 miles for operation and re-tighten if necessary.

**MAGNAFLOW:** 1901 Corporate Centre Dr - Oceanside, CA 92056 | 1(800)990-0905  
**Technical Support:** 1(800) 959-9226 | Email: [moreinfo@magnaflow.com](mailto:moreinfo@magnaflow.com)