



# INSTALLATION INSTRUCTIONS



2015 FORD FUSION 2.5L

PART NO. 19096

## BILL OF MATERIALS:

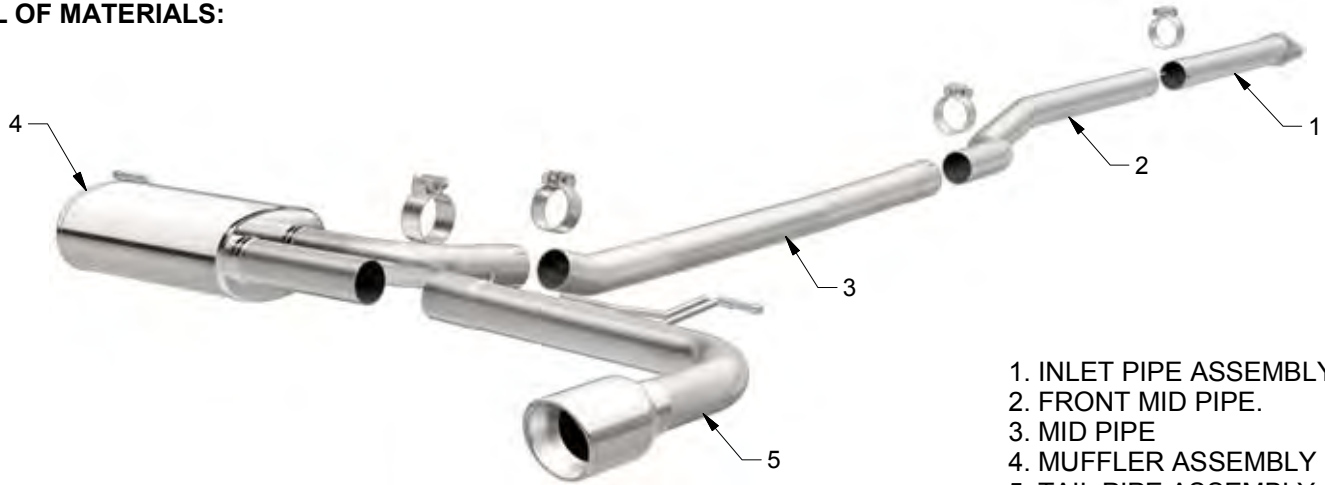

- 1. INLET PIPE ASSEMBLY
- 2. FRONT MID PIPE.
- 3. MID PIPE
- 4. MUFFLER ASSEMBLY
- 5. TAIL PIPE ASSEMBLY



WEAR SAFETY GLASSES



READ INSTRUCTIONS THOROUGHLY BEFORE INSTALLING PRODUCT

## SHOP SUPPLIES:



SPRAY LUBRICANT

To ease removal of existing exhaust components (especially on older vehicles) spray penetrating lubricant on all fasteners and hangers/insulators that will be loosened or removed and let soak before disassembly.

## HARDWARE KIT:

- 1. [4] 2.50" Clamp
- 2. [2] 10-1.50 Bolts

## MINIMUM REQUIRED TOOLS:



15mm



Hanger Tool (Or Pry Bar)

## MAGNAFLOW RECOMMENDS PROFESSIONAL INSTALLATION ON ALL THEIR PRODUCTS



**WARNING:** When working on, under, or around any vehicle exercise caution. Please allow the vehicle's exhaust system to cool before removal, as exhaust system temperatures may cause severe burns. If working without a lift always consult vehicle manual for correct lifting specifications. Always wear safety glasses and ensure a safe work area. Serious injury or death could occur if safety measures are not followed.

**ATTENTION:** Always install any supplied band or U-bolt clamps to the proper torque specifications of 40-45 ft-lbs for band clamps and 30-35 ft-lbs for U-bolt clamps. Over tightening will result in the clamp breaking and will NOT be warranted by MagnaFlow.

## INSTALLATION INSTRUCTIONS

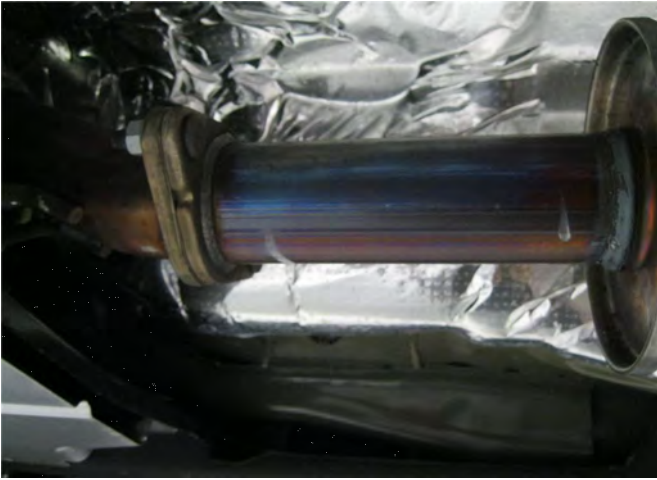

**Step 1.** To remove the OEM exhaust system you will first need to unbolt the OEM system inlet flange from the catalytic converter outlet pipe. Be sure to retain all mounting hardware as it will be needed to mount your new MAGNAFLOW system.



**Step 2.** Next, remove the welded hangers from the rubber insulators located on the OEM muffler and tail pipe assembly. The exhaust may now be removed in one piece.



**Step 3.** Begin installing the new system by loosely bolting the flange of the Inlet Pipe Assembly for the outlet flange of the OEM catalytic converter using the supplied bolts and OEM hardware. Keep all fasteners and clamps loose until final adjustment.



**Step 4.** Next slip the inlet of the Front Mid Pipe into the Inlet Pipe Assembly and loosely secure using the supplied 2.50" clamp.



**Step 5.** Install the Mid Pipe, Muffler Assembly and Tail Pipe Assembly using a similar method. Locate the welded hangers to the OEM rubber insulators.

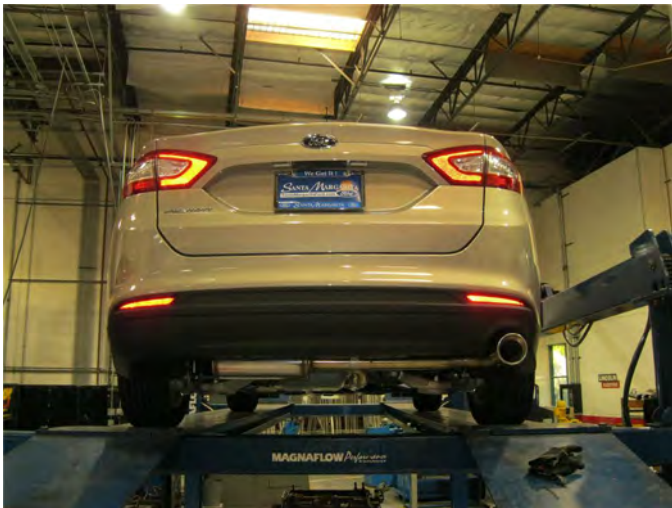

**Step 6.** Once a final position has been chosen for the new exhaust system, evenly tighten all clamps from front to rear using the torque specifications on page one of the instructions. Inspect all fasteners after 25-50 miles of operation and re-tighten if necessary.