

2011 Ford Mustang 3.7L V6 Street Axle Back System

Warning: When working on, under, or around any vehicle exercise caution. Please allow the vehicle's exhaust system to cool before removal, as exhaust system temperatures may cause severe burns. If working without a lift, always consult vehicle manual for correct lifting specifications. Always wear safety glasses and ensure a safe work area. Serious injury or death could occur if safety measures are not followed.

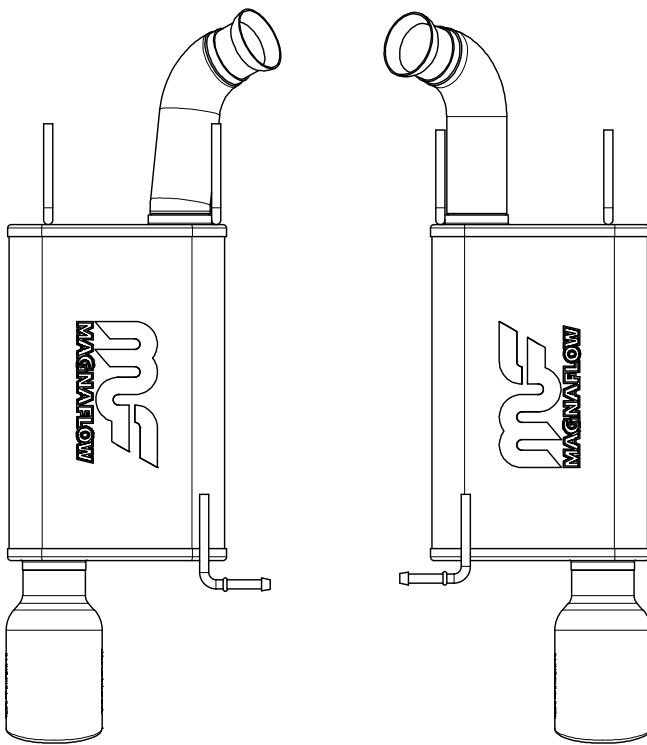

Step 1: (Carefully read all instructions before installation) To remove the OEM mufflers, first locate the ball flare clamp assembly attached to the inlet section of both mufflers. Remove the clamp from both the passenger and driver side, then remove the hangers from the rubber isolators (three on each side). (Do not damage the OEM rubber insulators as they will be reused to mount your new Magnaflow system). Use the OEM clamps from the muffler assemblies to secure the MAGNAFLOW muffler assemblies to the exhaust system. Locate all hangers to the rubber isolators.

Step 2: With all components mounted loosely, adjust the system for overall aesthetics and clearance of frame & bodywork. (MAGNAFLOW recommends at least 1/2" of clearance between the exhaust system and any body panels to prevent heat-related body damage or fire.)

Step 3: Once a final position has been chosen for the new system, evenly tighten all fasteners from front to rear. The OEM band clamps must be VERY tight to properly align the pipes and prevent leaks (Approximately 40ft-lbs). U-bolt clamps should be tightened to approximately 30-35ft-lbs. Inspect all fasteners after 25-50 miles of operation and retighten if necessary.

**** Magnaflow Performance Exhaust recommends professional installation on all their products**