



# INSTALLATION INSTRUCTIONS



'15 CHEVY COLORADO/GMC CANYON 2.5L/3.6L | PART NO. 19019

## BILL OF MATERIALS:

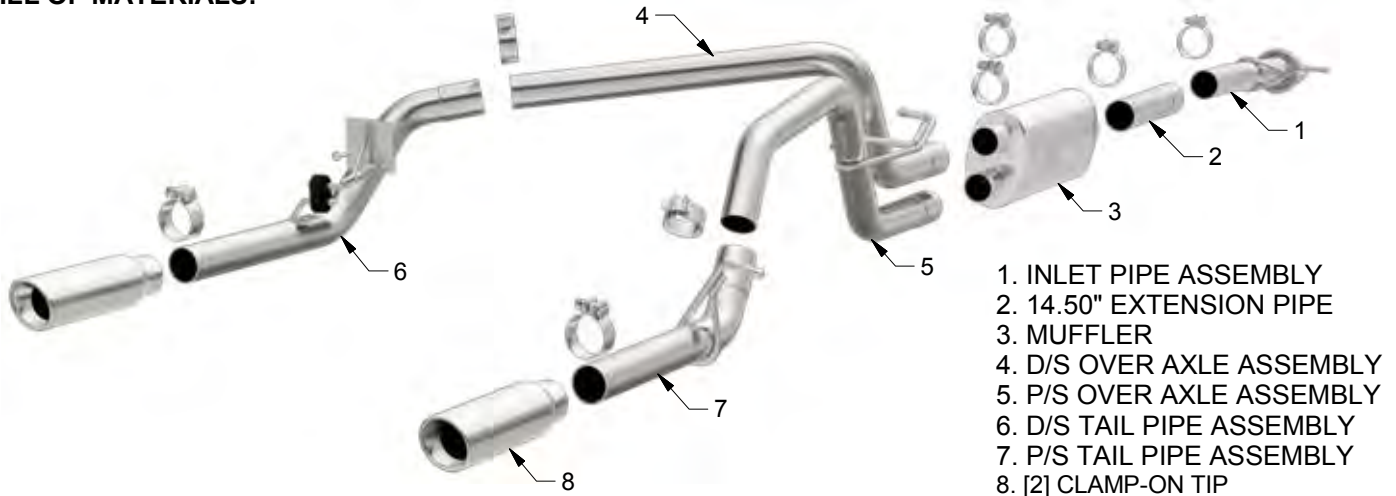

WEAR SAFETY GLASSES



READ INSTRUCTIONS THOROUGHLY BEFORE INSTALLING PRODUCT

## SHOP SUPPLIES:



SPRAY LUBRICANT

To ease removal of existing exhaust components (especially on older vehicles) spray penetrating lubricant on all fasteners and hangers/insulators that will be loosened or removed and let soak before disassembly.

## HARDWARE KIT:

- 1. [2] 3.00" Torca Clamp
- 2. [6] 2.50" Torca Clamp
- 3. [1] Hanger Rubber
- 4. [1] Hanger Bracket Assy.
- 5. [2] M8 Panel Nut
- 6. [2] M8 Bolt

## MINIMUM REQUIRED TOOLS:



Hanger Tool (Or Pry Bar)



15mm  
13mm

## MAGNAFLOW RECOMMENDS PROFESSIONAL INSTALLATION ON ALL THEIR PRODUCTS



**WARNING:** When working on, under, or around any vehicle exercise caution. Please allow the vehicle's exhaust system to cool before removal, as exhaust system temperatures may cause severe burns. If working without a lift always consult vehicle manual for correct lifting specifications. Always wear safety glasses and ensure a safe work area. Serious injury or death could occur if safety measures are not followed.

**ATTENTION:** Always install any supplied band or U-bolt clamps to the proper torque specifications of 40-45 ft-lbs for band clamps and 30-35 ft-lbs for U-bolt clamps. Over tightening will result in the clamp breaking and will NOT be warranted by MagnaFlow.

## INSTALLATION INSTRUCTIONS

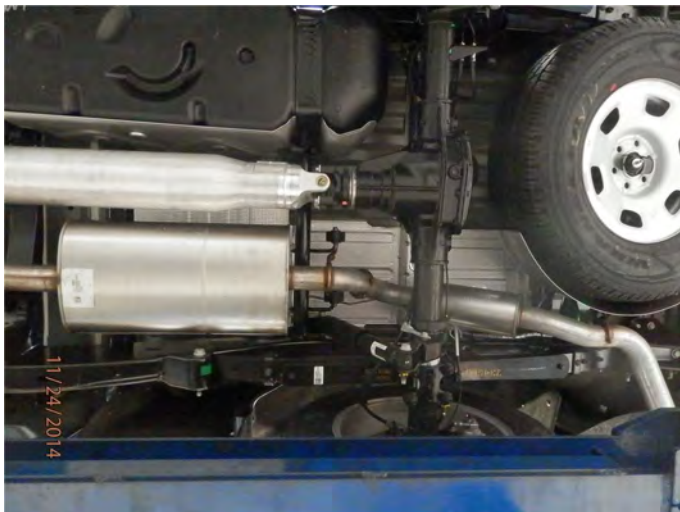
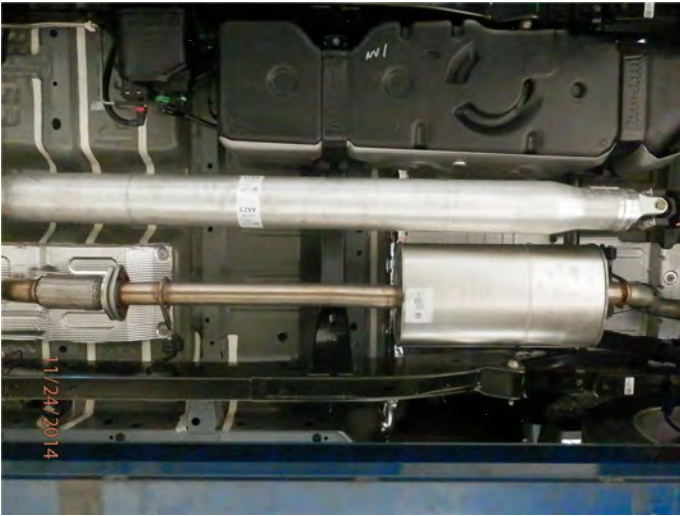

**Step 1.** To remove the OEM system you will need to unfasten the two bolt flange located behind the flex pipe. Working rearward (with the exhaust supported) extract the hangers from the rubber insulators and remove the OEM exhaust. Do not discard or damage the rubber insulators or fasteners as they will be used to install the new exhaust system.



**Step 2.** You will also need to remove the spare wheel and heat shield.



**Step 3.** Begin installing of the new system by attaching the Inlet Pipe Assembly to the flange re-using the OEM fasteners and inserting the hanger into the rubber insulator.



**Step 4.** If your vehicle has a Crew Cab/Standard Bed configuration you will need to include the supplied 14.50" Extension Pipe between the Inlet Pipe Assembly and the Muffler. For Crew Cab/Short Bed and Extended Cab/Standard Bed the Extension Pipe is omitted. Next loosely attach the Muffler to the Inlet Pipe Assembly using the supplied 3.00 clamps.

## INSTALLATION INSTRUCTIONS



**Step 5.** Continue the installation by loosely attaching the Over Axle Assemblies to the Muffler using a supplied 2.50" clamp and inserting the hanger into the rubber insulator.



**Step 6.** Loosely install the Tail Pipe Assemblies in a similar fashion using the supplied 2.50" clamps. Attach the supplied hanger bracket as shown using the supplied hardware. The mounting holes in the bracket will align with pre-existing holes in the vehicles sub frame. Attach the Hanger Bracket to the welded hanger on the drivers side Tail Pipe Assembly using the supplied Hanger Rubber.



**Step7.** Install the two Clamp-On Tips using the supplied 2.50" clamps.

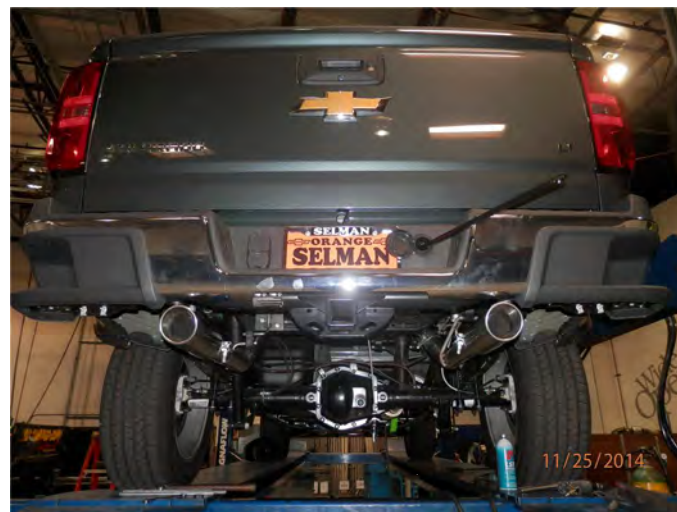

**Step 8.** Once a final position has been chosen for the new exhaust system, evenly tighten all clamps from front to rear using the torque specifications on page one of the instructions. Inspect all fasteners after 25-50 miles of operation and re-tighten if necessary.