



INSTALLATION INSTRUCTIONS



2019 DODGE CHARGER 3.6L | PART NO. 19522

BILL OF MATERIALS:

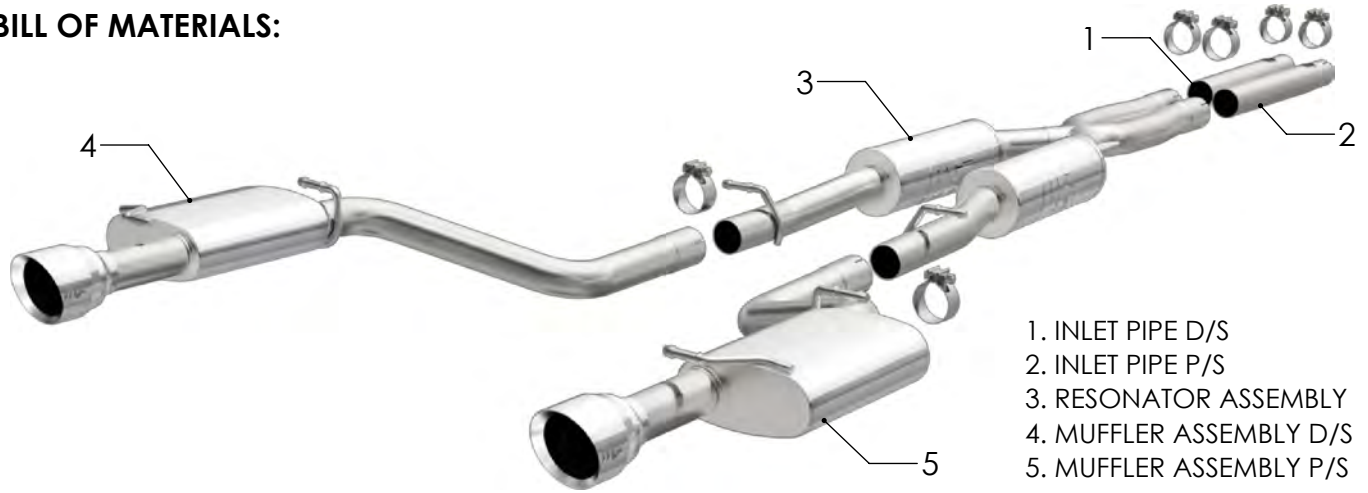

- 1. INLET PIPE D/S
- 2. INLET PIPE P/S
- 3. RESONATOR ASSEMBLY
- 4. MUFFLER ASSEMBLY D/S
- 5. MUFFLER ASSEMBLY P/S



WEAR SAFETY GLASSES



READ INSTRUCTIONS THOROUGHLY BEFORE INSTALLING PRODUCT



SPRAY LUBRICANT

To ease removal of existing exhaust components (especially on older vehicles) spray penetrating lubricant on all fasteners and hangers/insulators that will be loosened or removed and let soak before disassembly.

HARDWARE KIT:

- 1.[4] 2.50" Clamp
- 2.[2] 2.25" Clamp

MINIMUM REQUIRED TOOLS:



13mm, 15 mm



Hanger Tool (Or Pry Bar)

MAGNAFLOW RECOMMENDS PROFESSIONAL INSTALLATION ON ALL THEIR PRODUCTS



WARNING: When working on, under, or around any vehicle exercise caution. Please allow the vehicle's exhaust system to cool before removal, as exhaust system temperatures may cause severe burns. If working without a lift always consult vehicle manual for correct lifting specifications. Always wear safety glasses and ensure a safe work area. Serious injury or death could occur if safety measures are not followed.

ATTENTION: Always install any supplied band or U-bolt clamps to the proper torque specifications of 40-45 ft-lb for band clamps and 30-35 ft-lb for U-bolt clamps. Over tightening will result in the clamps breaking and will NOT be warranted by MagnaFlow.

MAGNAFLOW: 1901 Corporate Centre Dr - Oceanside, CA 92056 | 1(800)990-0905

Technical Support: 1(800) 959-9226 | Email: moreinfo@magnaflow.com

INSTALLATION INSTRUCTIONS

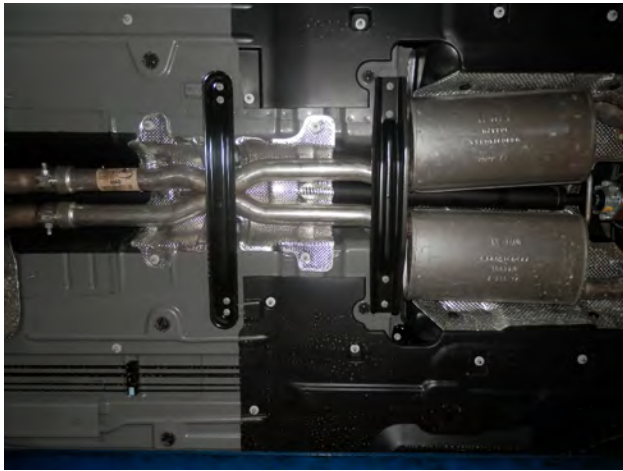

Step 1. To allow for removal of the OEM exhaust you will need to remove the underbody braces. Begin the removal of the OEM system by unfastening the X-Pipe inlets at the factory clamp locations. Next unfasten the two bolt flange behind the driver side muffler. Un-clip the ground strap from the passenger side hanger and working rearward (with the exhaust supported) extract the hangers from the rubber insulators and remove the OEM exhaust. Do not discard or damage the rubber insulators as they will be used to install the new exhaust system.

Step 2. Begin installation of the new system by attaching the Driver and Passenger side (Passenger is the longer of the two pipes) inlet pipes to the outlets of the OEM system using the supplied 2.25" clamps. Next attach the Resonator Assembly to the inlet pipes with supplied clamps and insert the hangers into the rubber insulators.

INSTALLATION INSTRUCTIONS



Step 3. Attach the Muffler Assemblies to the Resonator Assembly with supplied 2.50 Clamps and aligning them with the openings in the rear valance. Fit hangers into rubber insulators. Remember to re-attach the ground strap to the hanger. Finish the installation by mounting underbody braces.



Step 4. Once a final position has been chosen for the new exhaust system, evenly tighten all clamps from front to rear using the torque specifications on page one of the instructions. Inspect all fasteners after 25-50 miles of operation and re-tighten if necessary.