



INSTALLATION INSTRUCTIONS



JEEP GRAND CHEROKEE 5.7 | 3.6L

PART NO. 19606

BILL OF MATERIALS:

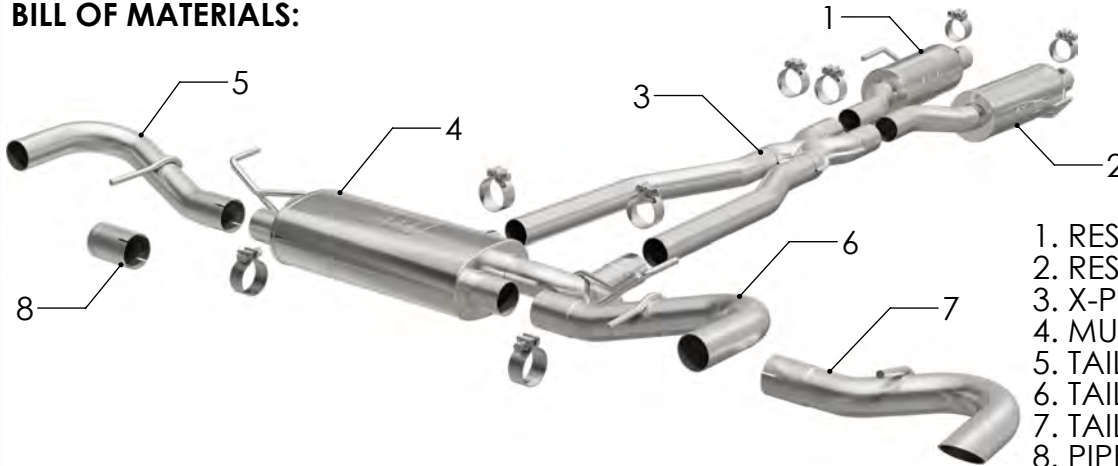

- 1. RESO ASSY D/S
- 2. RESO ASSY P/S
- 3. X-PIPE ASSY
- 4. MUFFLER ASSY
- 5. TAIL PIPE ASSY D/S
- 6. TAIL PIPE ASSY P/S
- 7. TAIL PIPE ASSY (3.6L)
- 8. PIPE CAP ASSY (3.6L)

SHOP SUPPLIES:

HARDWARE KIT:

- 1. [2] 2.36" Clamp
- 2. [6] 2.50" Clamp



WEAR SAFETY GLASSES



READ INSTRUCTIONS THOROUGHLY BEFORE INSTALLING PRODUCT



SPRAY LUBRICANT

To ease removal of existing exhaust components (especially on older vehicles) spray penetrating lubricant on all fasteners and hangers/insulators that will be loosened or removed and let soak before disassembly.

MINIMUM REQUIRED TOOLS:



13,15 mm



Hanger Tool (Or Pry Bar)

MAGNAFLOW RECOMMENDS PROFESSIONAL INSTALLATION ON ALL THEIR PRODUCTS



WARNING: When working on, under, or around any vehicle exercise caution. Please allow the vehicle's exhaust system to cool before removal, as exhaust system temperatures may cause severe burns. If working without a lift always consult vehicle manual for correct lifting specifications. Always wear safety glasses and ensure a safe work area. Serious injury or death could occur if safety measures are not followed.

ATTENTION: Always install any supplied band or U-bolt clamps to the proper torque specifications of 40-45 ft-lb for band clamps and 30-35 ft-lb for U-bolt clamps. Over tightening will result in the clamps breaking and will NOT be warranted by MagnaFlow.

MAGNAFLOW: 1901 Corporate Centre Dr - Oceanside, CA 92056 | 1(800)990-0905

Technical Support: 1(800) 959-9226 | Email: moreinfo@magnaflow.com

X INSTALLATION INSTRUCTIONS

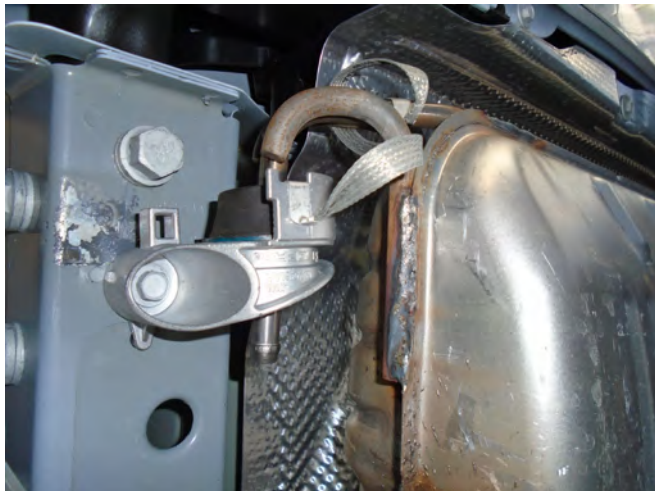

Step 1. To remove the OEM exhaust system begin by disengaging the grounding strip from the muffler assembly.

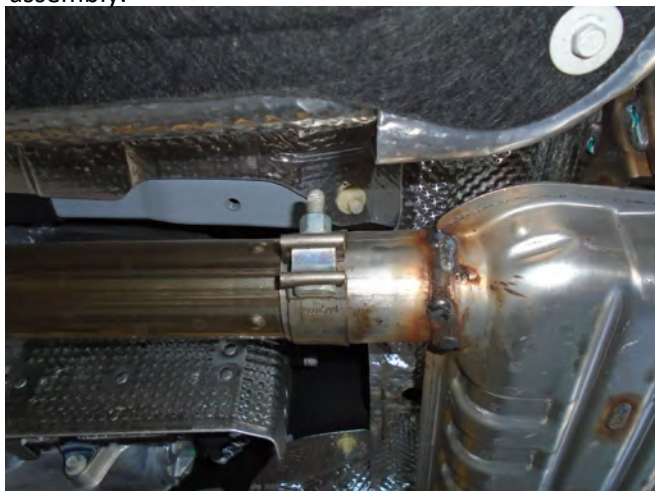

Step 2. Loosen the two clamps attaching the muffler assembly to the catalytic converter outlets. Disengage all welded hangers from the rubber insulator, do not discard as they will be needed to install the new MAGNAFLOW system. The OEM system can now be removed.

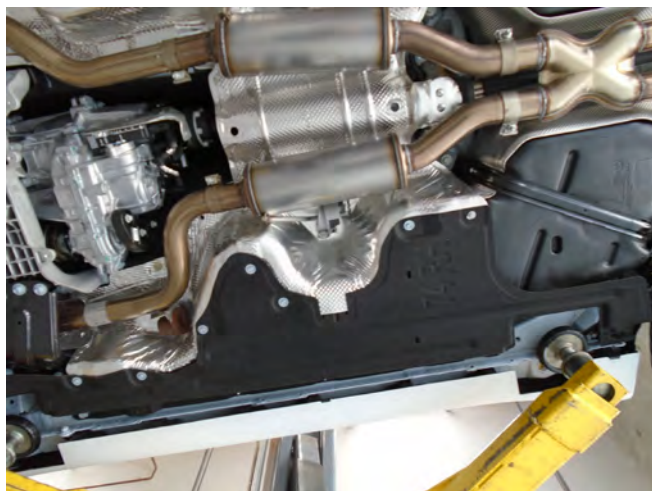

Step 3. Begin installing the new system by loosely attaching the Resonator Assembly inlets to the catalytic convert outlets using the supplied clamps. Engage the welded hangers to the rubber insulators.



Step 4. Install the X-Pipe Assembly by loosely securing both inlets to the Resonator Assembly outlets using the supplied clamps. The longer pipe should be oriented on the drivers side.

INSTALLATION INSTRUCTIONS



Step 5. Install the Muffler Assembly by loosely attaching the two inlet pipes to the X-Pipe Assembly outlet pipes using the supplied clamps. Engage the welded hangers to the rubber insulators.



Step 6. At this point the installation will deviate depending on whether you have the 5.7 or 3.6L vehicle (5.7L) Install the Tail Pipe Assemblies by locating the outlets through the rear valance tip. **(3.6L) Install the Passenger Side Tailpipe and the block off pipe.** loosely secure to the Muffler Assembly outlet using the supplied clamps. Engage the welded hangers to the rubber insulators.



Step 7. Finally, clip the grounding leads to the applicable locations they were removed from.



Step 8. Once a final position has been chosen for the new exhaust system, evenly tighten all clamps from front to rear using the torque specifications on page one of these instructions. Inspect all fasteners after 25-50 miles of operation and re-tighten if necessary.