



INSTALLATION INSTRUCTIONS



15-16 DODGE CHALLENGER 5.7L | PART NO. 19210

BILL OF MATERIALS:

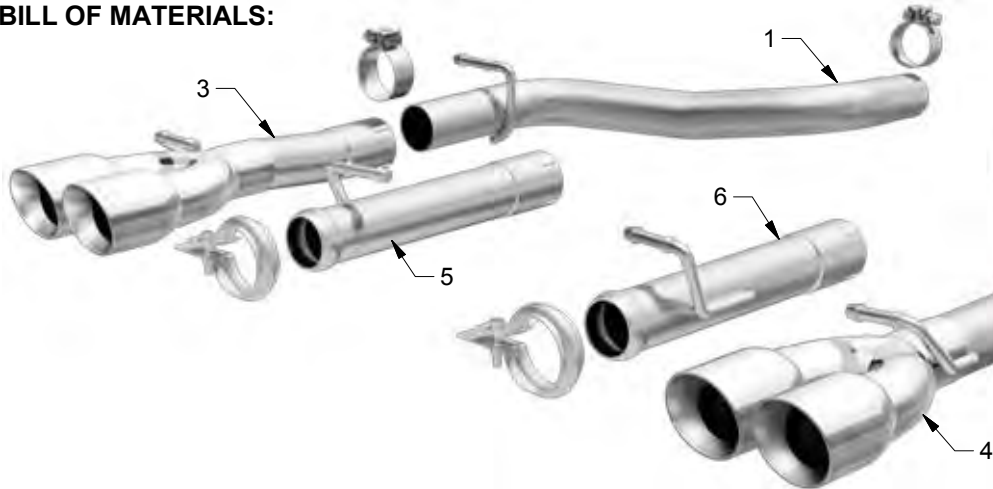

1. INLET PIPE ASSY D/S
2. INLET PIPE ASSY P/S
3. DUAL TIP ASSY D/S
4. DUAL TIP ASSY P/S
5. OEM TIP ASSY D/S
6. OEM TIP ASSY P/S



WEAR SAFETY GLASSES



READ INSTRUCTIONS THOROUGHLY BEFORE INSTALLING PRODUCT

SHOP SUPPLIES:



SPRAY LUBRICANT

To ease removal of existing exhaust components (especially on older vehicles) spray penetrating lubricant on all fasteners and hangers/insulators that will be loosened or removed and let soak before disassembly.

HARDWARE KIT:

1. [2] 2.25" Torca Clamp
2. [2] 2.50" Torca Clamp
3. [2] 3.00" Ball Clamp
4. [2] 8mm Bolts

MINIMUM REQUIRED TOOLS:



Hanger Tool (Or Pry Bar)



15mm
13mm



Sawzall or similar cutting device

MAGNAFLOW RECOMMENDS PROFESSIONAL INSTALLATION ON ALL THEIR PRODUCTS



WARNING: When working on, under, or around any vehicle exercise caution. Please allow the vehicle's exhaust system to cool before removal, as exhaust system temperatures may cause severe burns. If working without a lift always consult vehicle manual for correct lifting specifications. Always wear safety glasses and ensure a safe work area. Serious injury or death could occur if safety measures are not followed.

ATTENTION: Always install any supplied band or U-bolt clamps to the proper torque specifications of 40-45 ft-lbs for band clamps and 30-35 ft-lbs for U-bolt clamps. Over tightening will result in the clamp breaking and will NOT be warranted by MagnaFlow.

INSTALLATION INSTRUCTIONS



Step 1. Begin removal of the OEM system by cutting both side of the systems exhaust pipes 18.5" in front of the muffler face as shown in the attached pictures. Next un-clip the ground strap from the passenger side muffler hanger. With the exhaust supported extract the hangers from the rubber insulators and remove the OEM muffler assemblies. De-burr and smooth the cut pipes to prepare them for the new exhaust. Do not discard or damage the rubber insulators as they will be used to install the new exhaust system.



Step 2. Begin installation of your new system by slipping each Inlet Pipe Assembly over the cut OEM outlet pipes. Loosely secure using the supplied 2.25" clamps. Locate the welded hangers to the rubber insulators. Remember to re-attach the ground strap to the hanger



Step 3. At this point you have two options for tips. Magnaflow supplies a Quad tip setup that can be clamped to the Inlet Pipes and held in place with hangers and the installation is complete.



Step 4. To install the OEM tips they must first be removed from the stock exhaust system. You will need to loosen the tip clamps and break the weld holding them to the mufflers, both sides.



Step 5. Once the tips are removed install the OEM Tailpipe extensions using 2.50" Supplied clamps and fit into rubber insulators. Finish by installing the Stock tips to these extension pipes using the supplied ball clamp.

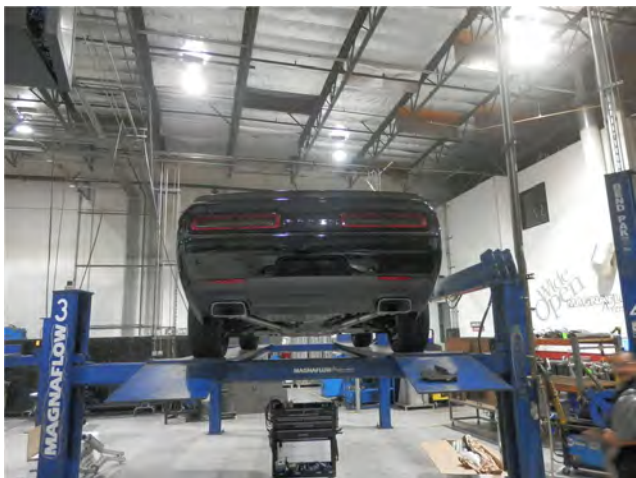

Step 6. Once a final position has been chosen for the new exhaust system, evenly tighten all clamps from front to rear using the torque specifications on page one of the instructions. Inspect all fasteners after 25-50 miles of operation and re-tighten if necessary.