

MAGNAFLOW

Mufflers, Converters,
Systems and Tips

Performance
EXHAUST

INSTALLATION INSTRUCTIONS FOR 16649

2007- TOYOTA FJ CRUISER - V6 4.0L

Warning: When working on, under, or around any vehicle exercise caution. Please allow the vehicle's exhaust system to cool before removal, as exhaust system temperatures may cause severe burns. If working without a lift, always consult vehicle manual for correct lifting specifications. Always wear safety glasses and ensure a safe work area. Serious injury or death could occur if safety measures are not followed.

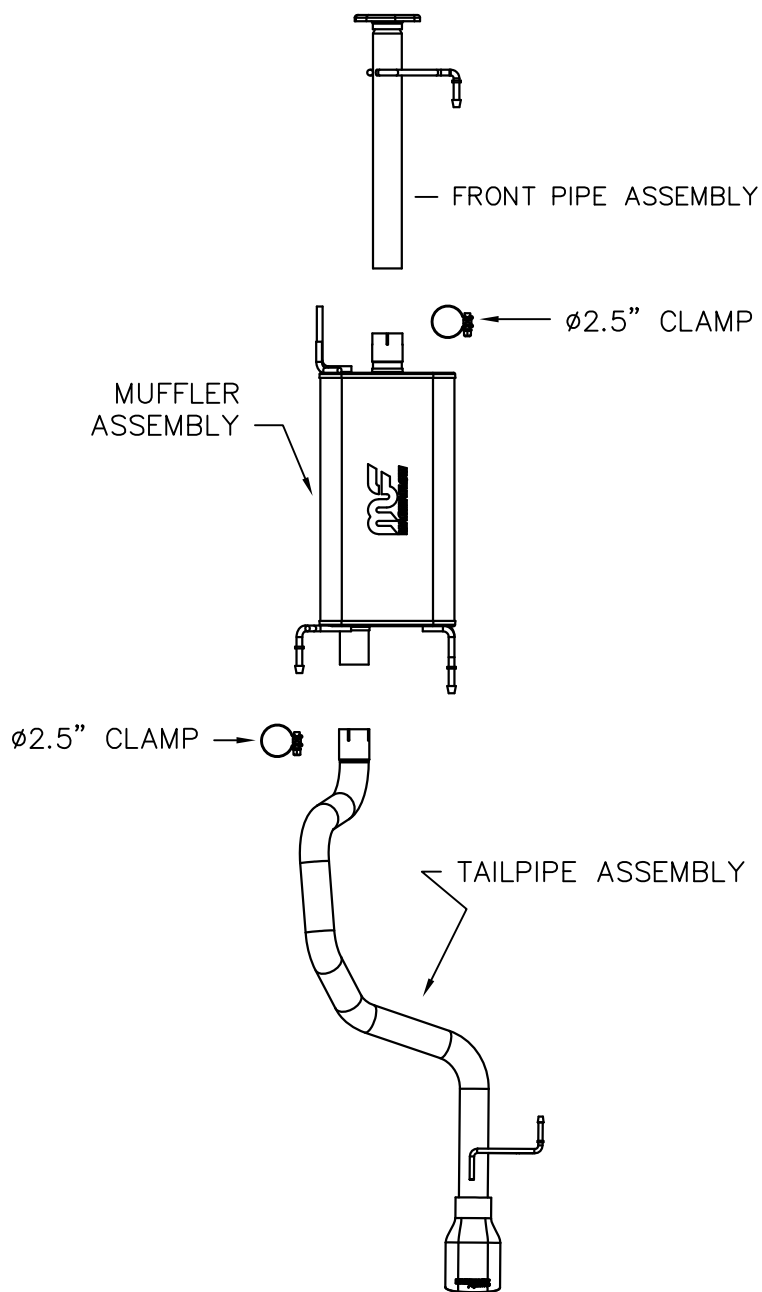

Step 1: (Carefully read all instructions before installation) Disconnect the vehicle's battery before removal of the OEM exhaust. This will allow the computer to reset itself with the new system, and prevent electrical accidents. Begin by unbolting the tailpipe at the flange connecting it to the muffler. Because the bolts may be stubborn, it may hasten the process to simply cut the tailpipe where it goes over the axle. Do not discard or damage the OEM fasteners or rubber insulators, as they may be reused to mount the new system. Disengage the rubber insulators and remove the tailpipe. Remove the muffler by unbolting it at the flange, and by disengaging the rubber insulators as before.

Step 2: Begin installing the new exhaust by bolting the front pipe assembly to the OEM flange using the OEM hardware. Leave all clamps and fasteners loose for final adjustment of the complete system. Next connect the muffler to the front pipe by using a provided 2.5" band clamp, and by fitting the welded hangers into the rubber insulators. Install the tailpipe assembly in a similar fashion.

Step 3: With all components mounted loosely, adjust the system for overall aesthetics and clearance of frame & bodywork. (MAGNAFLOW recommends at least 1/2" of clearance between the exhaust system and any body panels to prevent heat-related body damage or fire.)

Step 4: Once a final position has been chosen for the new system, evenly tighten all fasteners from front to rear. The supplied band clamps must be VERY tight to properly align the pipes and prevent leaks (Approximately 65ft-lbs). U-bolt clamps should be tightened to approximately 40ft-lbs. Inspect all fasteners after 25-50 miles of operation and retighten if necessary.

**MAGNAFLOW Performance Exhaust recommends professional installation on all their products*

Technical support: 1-800-959-9226 ext. 4500

MAGNAFLOW Performance Exhaust - 22961 Arroyo Vista - Rancho Santa Margarita, CA 92688