

2014 Chevrolet Silverado 5.3L

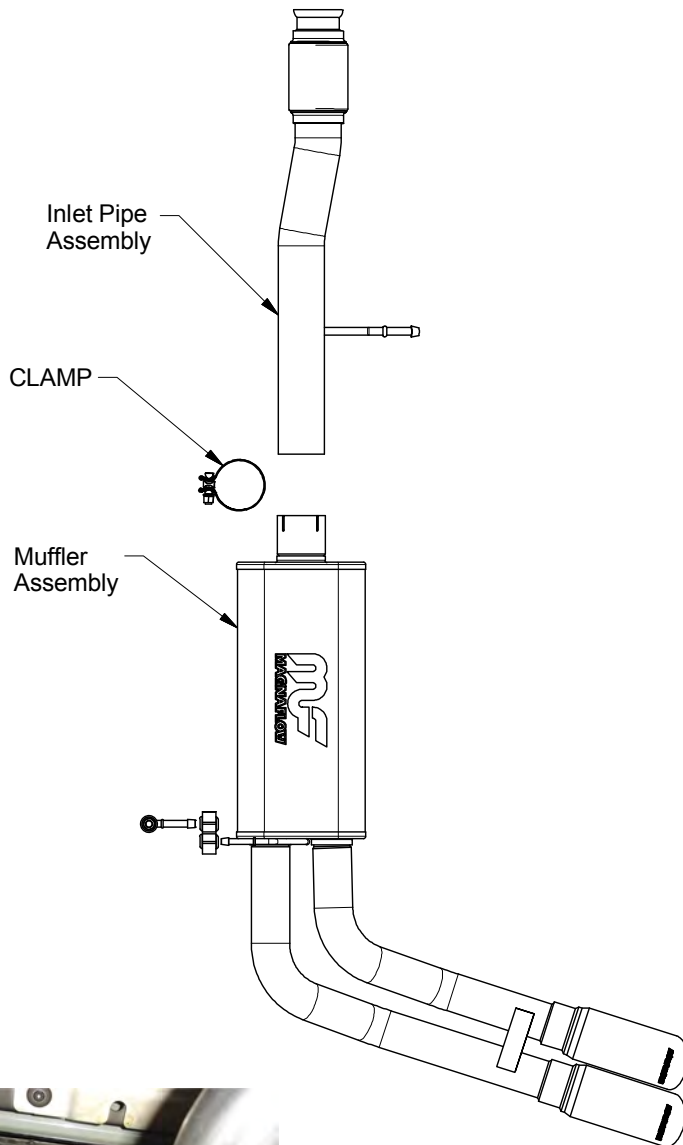

Fig. 1

Warning: When working on, under, or around any vehicle exercise caution. Please allow the vehicle's exhaust system to cool before removal, as exhaust system temperatures may cause severe burns. If working without a lift, always consult vehicle manual for correct lifting specifications. Always wear safety glasses and ensure a safe work area. Serious injury or death could occur if safety measures are not followed.

Step 1: (Carefully read all instructions before installation) To remove the OEM exhaust system, you will first need to unbolt the muffler inlet at the clamp junction behind the catalytic converter. Do not discard or damage the OEM fasteners and rubber insulators, as they will be reused to mount the new system. Disengage the welded hangers from the OEM rubber insulators and extract the system.

Step 2: Install the new inlet pipe assembly at the ball flare using the OEM fasteners. Leave all clamps and fasteners loose for final adjustments of the new system. Using the supplied 3.00" clamp, install the muffler/tailpipe assembly, and insert the welded hanger into the OEM rubber insulator. Install the threaded hanger in a pre-drilled hole in the frame as shown in Fig.1.

Step 3: With all components mounted loosely, adjust the system for overall aesthetics and clearance of frame & bodywork. (MAGNAFLOW recommends at least 1/2" of clearance between the exhaust system and any body panels to prevent heat-related body damage or fire.)

Step 4: Once a final position has been chosen for the new system, evenly tighten all fasteners from front to rear. The supplied band clamps must be VERY tight to properly align the pipes and prevent leaks (Approximately 40ft-lbs). Inspect all fasteners after 25-50 miles of operation and retighten if necessary.

**** Magnaflow Performance Exhaust recommends professional installation on all their products**