



# INSTALLATION INSTRUCTIONS



2015 DODGE CHALLENGER 5.7L | PART NO. 19209

## BILL OF MATERIALS:

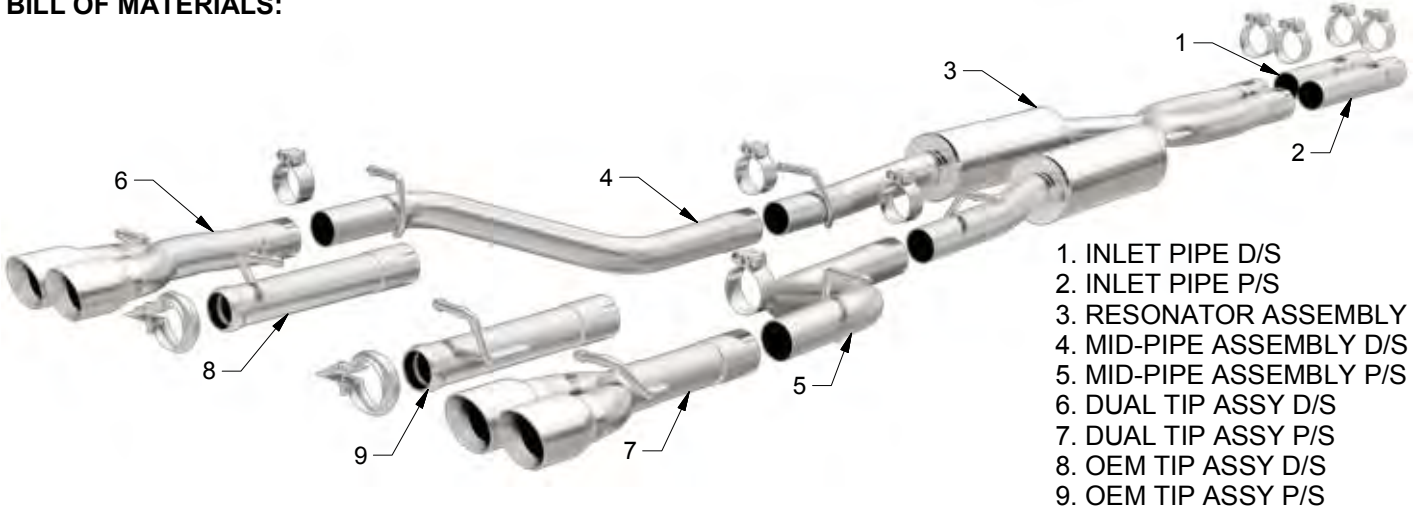

- 1. INLET PIPE D/S
- 2. INLET PIPE P/S
- 3. RESONATOR ASSEMBLY
- 4. MID-PIPE ASSEMBLY D/S
- 5. MID-PIPE ASSEMBLY P/S
- 6. DUAL TIP ASSY D/S
- 7. DUAL TIP ASSY P/S
- 8. OEM TIP ASSY D/S
- 9. OEM TIP ASSY P/S



WEAR SAFETY GLASSES



READ INSTRUCTIONS THOROUGHLY BEFORE INSTALLING PRODUCT

## SHOP SUPPLIES:



SPRAY LUBRICANT

To ease removal of existing exhaust components (especially on older vehicles) spray penetrating lubricant on all fasteners and hangers/insulators that will be loosened or removed and let soak before disassembly.

## HARDWARE KIT:

- 1. [8] 2.50" Torca Clamp
- 2. [2] 3.00" Ball Clamp
- 3. [2] 8mm Bolts

## MINIMUM REQUIRED TOOLS:



Hanger Tool (Or Pry Bar)



15mm  
13mm

## MAGNAFLOW RECOMMENDS PROFESSIONAL INSTALLATION ON ALL THEIR PRODUCTS



**WARNING:** When working on, under, or around any vehicle exercise caution. Please allow the vehicle's exhaust system to cool before removal, as exhaust system temperatures may cause severe burns. If working without a lift always consult vehicle manual for correct lifting specifications. Always wear safety glasses and ensure a safe work area. Serious injury or death could occur if safety measures are not followed.

**ATTENTION:** Always install any supplied band or U-bolt clamps to the proper torque specifications of 40-45 ft-lbs for band clamps and 30-35 ft-lbs for U-bolt clamps. Over tightening will result in the clamp breaking and will NOT be warranted by MagnaFlow.

MAGNAFLOW: 22961 Arroyo Vista - Rancho Santa Margarita, CA 92688 | 1(800) 990-0905  
Technical Support: 1(800) 959-9226 | Email: [moreinfo@magnaflow.com](mailto:moreinfo@magnaflow.com)

## INSTALLATION INSTRUCTIONS

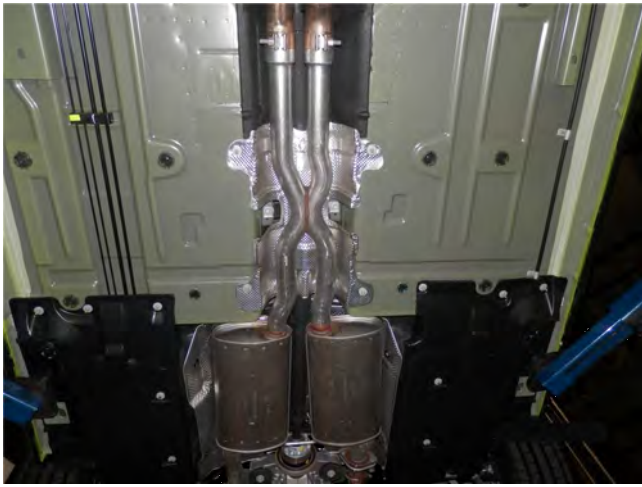

**Step 1.** To begin the removal of the OEM system you will need to unfasten the X-Pipe inlets at factory clamp locations. Next un-clip the ground strap from the passenger side muffler hanger. Working rearward (with the exhaust supported) extract the hangers from the rubber insulators and remove the OEM exhaust. Do not discard or damage the rubber insulators as they will be used to install the new exhaust system.



**Step 2.** Begin installing of the new system by attaching the Driver and Passenger side (Passenger is the longer of the two pipes) inlet pipes to the outlets of the OEM system using the supplied 2.50" clamps. Next attach the Resonator Assembly to the inlet pipes with supplied clamps and insert the hangers into the rubber insulators.



**Step 3.** Attach the Mid-pipes to the Resonator Assembly with supplied 2.50 Clamps and fit hangers into rubber insulators. Remember to re-attach the ground strap to the hanger. At this point you have two options for tips. Magnaflow supplies a Quad tip setup that can be clamped to the Mid-Pipes and held in place with hangers and the installation is complete.



**Step 4.** To install the OEM tips they must first be removed from the stock exhaust system. You will need to loosen the tip clamps and break the weld holding them to the mufflers, both sides.



**Step 5.** Once the tips are removed install the OEM Tailpipe extensions using 2.50" Supplied clamps and fit into rubber insulators. Finish by installing the Stock tips to these extension pipes using the supplied ball clamp.

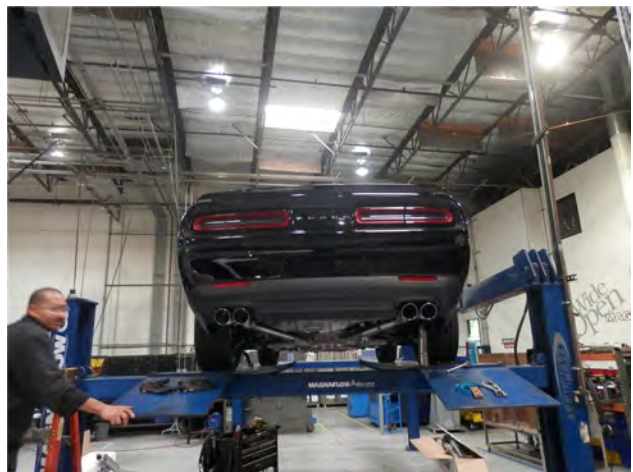

**Step 6.** Once a final position has been chosen for the new exhaust system, evenly tighten all clamps from front to rear using the torque specifications on page one of the instructions. Inspect all fasteners after 25-50 miles of operation and re-tighten if necessary.