



INSTALLATION INSTRUCTIONS



2015 FORD MUSTANG 2.3L | PART NO. 19191

BILL OF MATERIALS:

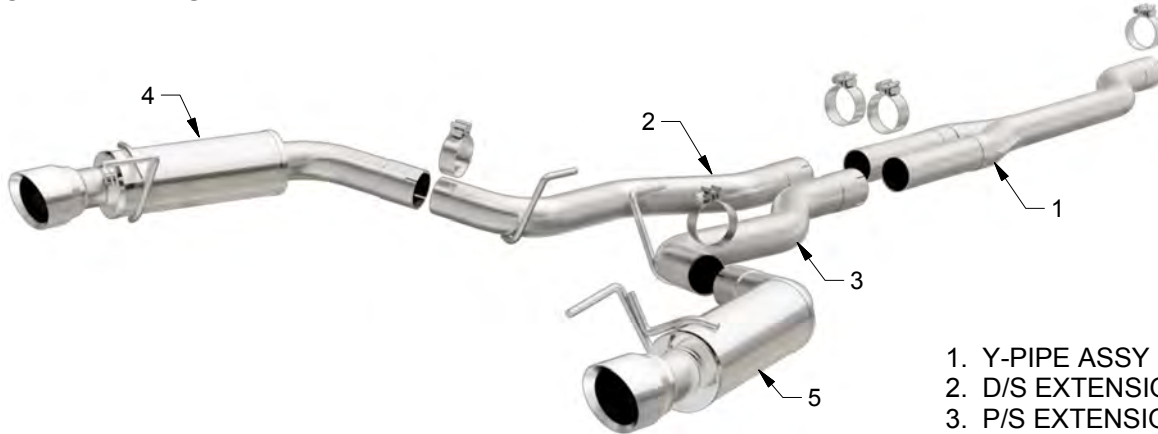

- 1. Y-PIPE ASSY
- 2. D/S EXTENSION PIPE ASSY
- 3. P/S EXTENSION PIPE ASSY
- 4. D/S MUFFLER ASSY
- 5. P/S MUFFLER ASSY



WEAR SAFETY GLASSES



READ INSTRUCTIONS THOROUGHLY BEFORE INSTALLING PRODUCT

SHOP SUPPLIES:



SPRAY LUBRICANT

To ease removal of existing exhaust components (especially on older vehicles) spray penetrating lubricant on all fasteners and hangers/insulators that will be loosened or removed and let soak before disassembly.

HARDWARE KIT:

- 1. [4] 2.50" Clamp

MINIMUM REQUIRED TOOLS:



15mm
14mm



Hanger Tool
(Or Pry Bar)

MAGNAFLOW RECOMMENDS PROFESSIONAL INSTALLATION ON ALL THEIR PRODUCTS



WARNING: When working on, under, or around any vehicle exercise caution. Please allow the vehicle's exhaust system to cool before removal, as exhaust system temperatures may cause severe burns. If working without a lift always consult vehicle manual for correct lifting specifications. Always wear safety glasses and ensure a safe work area. Serious injury or death could occur if safety measures are not followed.

ATTENTION: Always install any supplied band or U-bolt clamps to the proper torque specifications of 40-45 ft-lbs for band clamps and 30-35 ft-lbs for U-bolt clamps. Over tightening will result in the clamp breaking and will NOT be warranted by MagnaFlow.

MAGNAFLOW: 22961 Arroyo Vista - Rancho Santa Margarita, CA 92688 | 1(800) 990-0905

Technical Support: 1(800) 959-9226 | Email: moreinfo@magnaflow.com

19191 10/29/14 REV 000

INSTALLATION INSTRUCTIONS



Step 1. (Notice: This exhaust system fits on both convertible and coupe Mustangs. To install the system on a convertible you must first remove all underbody bracing.) Begin removing the exhaust system by loosening the clamp located in front of the resonator. Next, working front to rear extract the hangers from the rubber insulators and remove the OEM system. Retain insulators and clamps as they will be used to install the new system.



Step 2. Begin installation of the new system by loosely attaching the Y-Pipe Assembly to the outlets using the OEM clamp. Leave all clamps loose until final adjustment.



Step 3. Next attach the Extension Pipe Assemblies to the Y-Pipe using the supplied 2.50" clamps and fitting the hangers into the rubber insulators.



Step 4. Finish the initial installation by fitting the Muffler Assemblies onto the Extension pipes using the supplied 3.00" clamps and inserting the hangers into the rubber insulators.



Step 5. Once a final position has been chosen for the new exhaust system, evenly tighten all clamps from front to rear using the torque specifications on page one of the instructions. Inspect all fasteners after 25-50 miles of operation and re-tighten if necessary.