



# INSTALLATION INSTRUCTIONS



FORD F-150 RAPTOR (R) 3.5/5.2L | PART NO. 19651

## BILL OF MATERIALS:

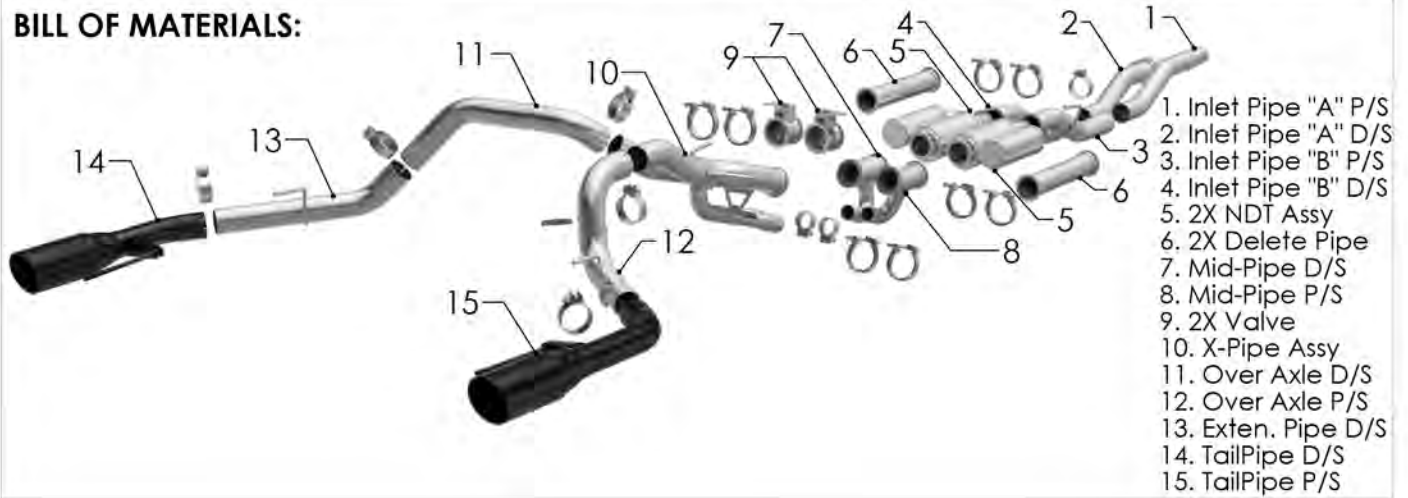

## SHOP SUPPLIES:

## HARDWARE KIT:



WEAR SAFETY GLASSES



READ INSTRUCTIONS THOROUGHLY BEFORE INSTALLING PRODUCT



SPRAY LUBRICANT

To ease removal of existing exhaust components (especially on older vehicles) spray penetrating lubricant on all fasteners and hangers/insulators that will be loosened or removed and let soak before disassembly.

1. [2] 2.00 Torca clamp
2. [6] 3.00 Torca clamp
3. [2] Bolt M6-1.25x25mm
4. [2] Spacer M6
5. [2] Nut M6-1.25
6. [3] 3.00 Hose Clamp
7. [1] 2-Bolt Flange
8. [8] 3.00 V-Band

## MINIMUM REQUIRED TOOLS:



Saw (Or Other Cutting Tool)



13,15,16,18mm



Hanger Tool (Or Pry Bar)

## MAGNAFLOW RECOMMENDS PROFESSIONAL INSTALLATION ON ALL THEIR PRODUCTS



**WARNING:** When working on, under, or around any vehicle exercise caution. Please allow the vehicle's exhaust system to cool before removal, as exhaust system temperatures may cause severe burns. If working without a lift always consult vehicle manual for correct lifting specifications. Always wear safety glasses and ensure a safe work area. Serious injury or death could occur if safety measures are not followed.

**ATTENTION:** Always install any supplied band or U-bolt clamps to the proper torque specifications of 40-45 ft-lb for band clamps and 30-35 ft-lb for U-bolt clamps. Over tightening will result in the clamps breaking and will NOT be warranted by MagnaFlow.

MAGNAFLOW: 1901 Corporate Centre Dr - Oceanside, CA 92056 | 1(800)990-0905

Technical Support: 1(800) 959-9226 | Email: [moreinfo@magnaflow.com](mailto:moreinfo@magnaflow.com)

## INSTALLATION INSTRUCTIONS

This MagnaFlow xMOD kit encompasses both Raptor (3.5L) and Raptor R (5.2L) configurations and also allows for different sound profiles. The supplied inlet pipes (A) are engineered to to work with the Raptor R (5.2L) to remove the OE resonators. They can be used with the Raptor (3.5L) to replace the Loop pipe inlet assembly but it is not recommended. The Exhaust valves on these vehicles also vary, please see the addendum at the end of the install sheet if your vehicle falls into this category.

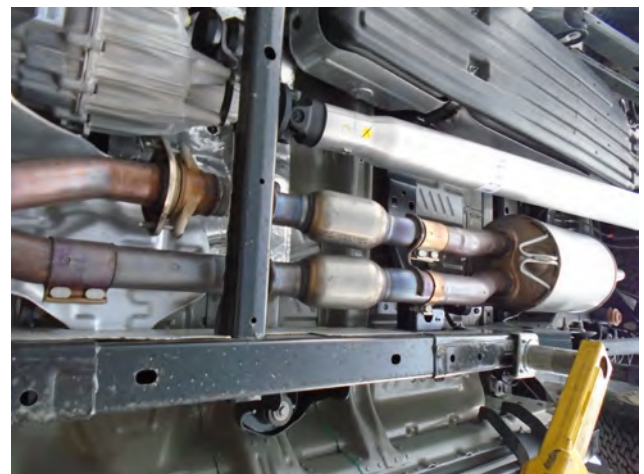

**Step 1:** This kit supplies Inlet pipes to replace the resonator pipes on the 5.2L(R) and can replace the equal length (Loop) pipe assembly on the 3.5L. These supplied pipes can be used for a more aggressive sound but aren't necessary to complete the installation. If using these pipes begin removal at Step 2. if not continue to Step 3.

**Step 2:** Begin by unfastening the inlet flange and slip clamp.

## INSTALLATION INSTRUCTIONS



**Step 3:** Begin removal of your OE system by first loosening the clamps in front of the muffler assembly and un-plugging the electrical connections to the valves. Disengage all welded hangers from the rubber insulators. Retain the large slide clamp(s) and rubber insulators as they will be used to install your new system.



**Step 4:** Next loosen the clamps on both pipes where they pass over the rear axle. With the exhaust supported working front to back remove the OE exhaust system. You will also need to remove the spare tire to install this system. You are now ready to install your new MAGNAFLOW exhaust system

**NOTICE:** At this point you will need to determine which valves are on your vehicle, and which valves are included with your 19651 kit.

If your factory muffler valve assembly is part ML3Z 5230-GF you have the first version of valves. If your 19651 kit includes valves without a valve coupler assembly you may continue installation. If your 19651 kit includes valves that contain a valve coupler assembly you will need to contact MagnaFlow customer service at 1-800-990-0905 (option 2) or email [moreinfo@magnaflow.com](mailto:moreinfo@magnaflow.com) for a warranted replacement set of valves.

If your factory muffler valve assembly is part ML3Z 5230-L you have the second version of valves. If your 19651 kit includes valves with a valve coupler assembly you may continue installation. If your 19651 kit includes valves that do not contain a valve coupler assembly you will need to contact MagnaFlow customer service at 1-800-990-0905 (option 2) or email [moreinfo@magnaflow.com](mailto:moreinfo@magnaflow.com) for a warranted replacement set of valves.

**MagnaFlow Version 2 Valves Will Have An Additional Valve Coupler Assembly**

**MagnaFlow Version 1 Valves Will Not Have This Coupler**

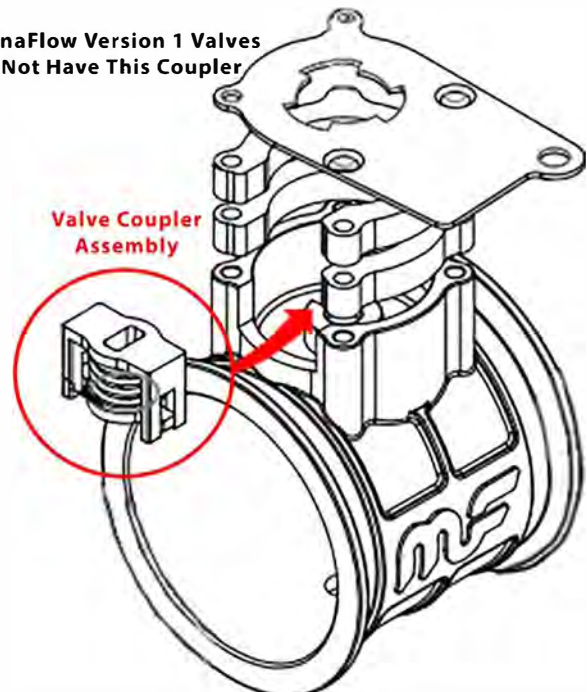

## INSTALLATION INSTRUCTIONS

**Step 5:** Once the OE exhaust is on the ground use the following process for installing the MagnaFlow valves. It is best to complete the process one side at a time to avoid confusion, It may also help to take pictures of the valves on the OE exhausts to help when assembling the new MagnaFlow valves



**Step 6:** Begin by removing the valve motor assembly from the OE exhaust. At this point you will need to plug the motor assembly back into the wire loom on the vehicle to reset the motor location, this is done by opening/closing the driver side door. Remove the Motor assembly, it is now ready to be installed onto the MagnaFlow valve.

## INSTALLATION INSTRUCTIONS



**Step 7:** Locate the motor onto the valve by aligning the locking tabs and secure by rotating clockwise into place (the mounting hole will line up). At this point you can determine if the motor was reset correctly. With the motor installed and keyed into place the valve butterfly should be closed. If it is not completely closed, repeat the motor reset process. Complete the assembly by securing the motor with the supplied M6 bolt and spacer. After completing both valve motor swaps set the valves aside and resume installing the exhaust.

## INSTALLATION INSTRUCTIONS



**Step 8:** Before beginning the exhaust installation the heatshield from the OE system needs to be moved to the MagnaFlow system. Cut the retaining straps securing the heatshield. Move it over the MagnaFlow Over Axle Assembly and secure using the supplied 3.00" worm drive clamps.

## INSTALLATION INSTRUCTIONS

**Step 9:** MagnaFlow supplies this kit with two build options giving the ability to use the NDT Resonator or Delete Pipes depending on preference.

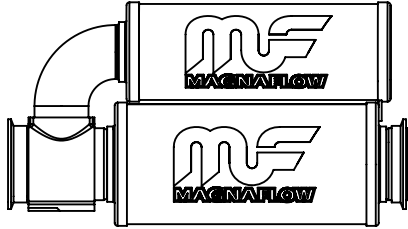

**Street:** Aggressive and throaty growl mixed with NDT (non drone technology) chambered exhaust tones for a street performance sound.



**Race:** Straight pipe muffler delete with rasp and pop reminiscent of chambered exhaust.

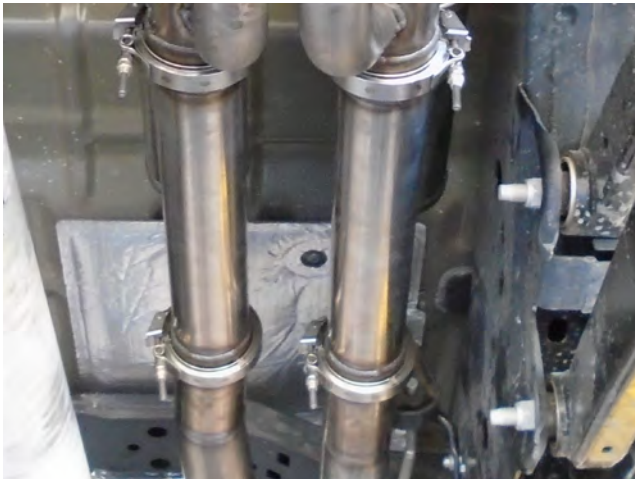

**Step 10:** Once an xMod option has been chosen, loosely attach the assembly to the flange ring outlet of the Inlet Assemblies using the supplied V-Band clamps.

**NOTE:** There are 2 spare V-Band clamps in the hardware kit.



**Step 11:** Loosely install the two Mid-Pipe Assemblies using the supplied clamps. Orientate as shown

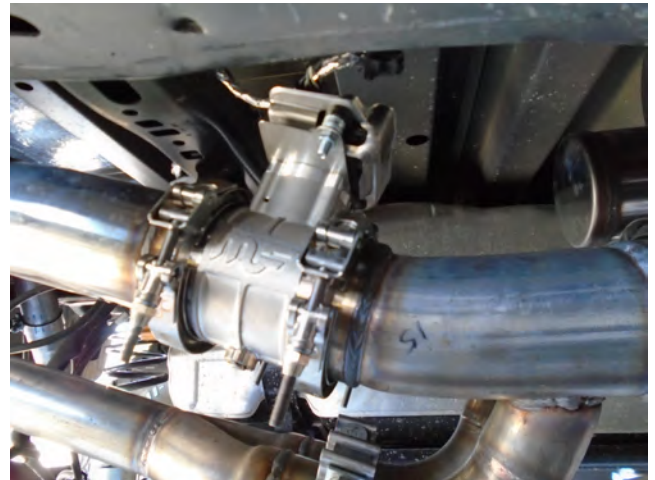

**Step 12:** Next install the valves using the supplied clamps and fit the electrical plugs.

## X INSTALLATION INSTRUCTIONS



**Step 13:** loosely Fit the X-Pipe Assembly using the supplied 3.00" clamps and fitting the bypass pipe to the Mid Pipe Bypass Pipes using the supplied 2.00" clamps.



**Step 14:** Attach the D/S extension Pipe and the Mid-Pipe Assemblies to the X-Pipe using the supplied clamps and fitting the hangers into rubber insulators.



**Step 15:** Attach the Tailpipe Assemblies to the Mid-Pipe Assemblies using the supplied clamps and fitting the hangers into rubber insulators.

## INSTALLATION INSTRUCTIONS



**Step 16:** Once a final position has been chosen for the new exhaust system, evenly tighten all clamps and fasteners, from front to rear, using the torque specifications on page one of the instructions. Inspect all fasteners after 25-50 miles of operation and re-tighten if necessary.

## INSTALLATION INSTRUCTIONS



**Supplemental step 1 :** The valves are supplied assembled, it is necessary to remove the top plate to perform the next step. Remove the Clocking Spring (heatsink) from the OE assembly and install it onto the Magnaflow valve as shown.

## INSTALLATION INSTRUCTIONS

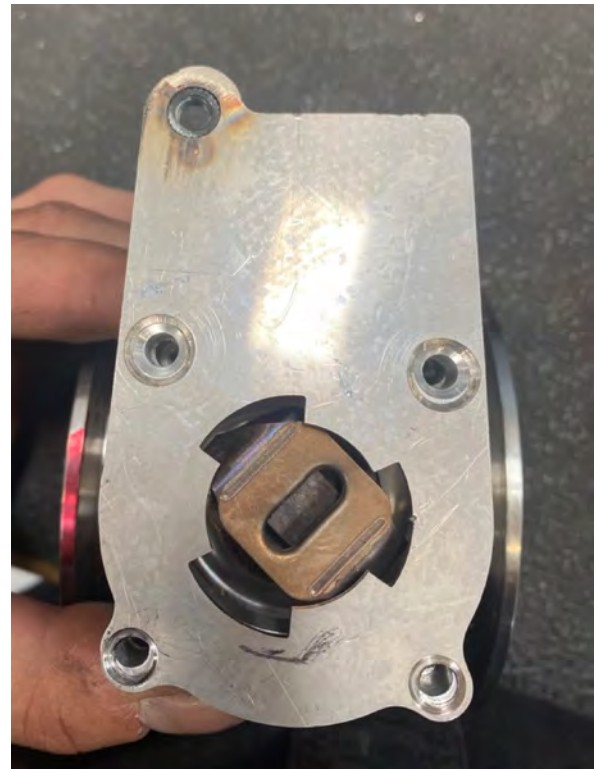

**Supplemental step 2 :** Once the Clocking Spring is installed reassemble the valve in the order it was disassembled. Take note that the machined spacers have two countersunk holes and they must correspond with the countersunk holes in the plate and the flat head machine screws.

**MAGNAFLOW:** 1901 Corporate Centre Dr - Oceanside, CA 92056 | 1(800)990-0905  
**Technical Support:** 1(800) 959-9226 | Email: [moreinfo@magnaflow.com](mailto:moreinfo@magnaflow.com)

19651 3/10/2023 REV 000

# IMPORTANT



## Need assistance?

Scan code using your mobile device to visit our help center for instant answers to common questions

## Warranty &

## Returns

For inquiries about warranty and returns, or to start a return, contact MagnaFlow directly:



+1 800 959 9226



[moreinfo@magnaflow.com](mailto:moreinfo@magnaflow.com)



[magnaflow.com/pages/contact-us](https://magnaflow.com/pages/contact-us)



[magnaflow.com/a/returns](https://magnaflow.com/a/returns)



MagnaFlow  
3937 Ocean Ranch Blvd  
Oceanside, CA 92056

© MagnaFlow is a registered trademark of Car Sound Exhaust System, Inc.  
All rights reserved.  
ISO 9001:2008 Certified — Registered since 2000

v2024.01\_108.20