



INSTALLATION INSTRUCTIONS



2015 ALFA ROMEO 4C

PART NO. 19292

BILL OF MATERIALS:

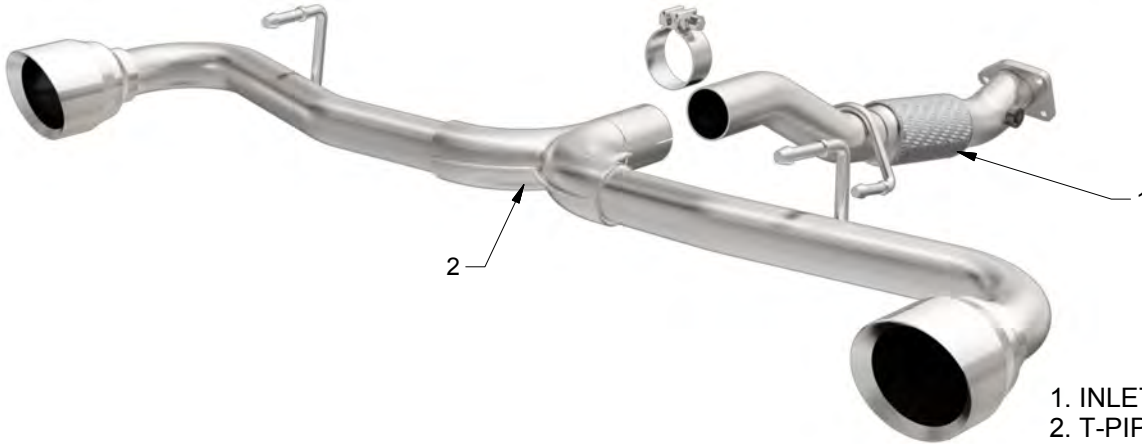

- 1. INLET PIPE ASSEMBLY
- 2. T-PIPE ASSEMBLY
- 3. D/S TAIL PIPE ASSEMBLY
- 4. P/S TAIL PIPE ASSEMBLY



WEAR SAFETY GLASSES



READ INSTRUCTIONS THOROUGHLY BEFORE INSTALLING PRODUCT



SPRAY LUBRICANT

To ease removal of existing exhaust components (especially on older vehicles) spray penetrating lubricant on all fasteners and hangers/insulators that will be loosened or removed and let soak before disassembly.

HARDWARE KIT:

- 1.[1] 2.50" Clamp
- 2.[2] 2.25" Clamp

MINIMUM REQUIRED TOOLS:



15mm



Hanger Tool (Or Pry Bar)

MAGNAFLOW RECOMMENDS PROFESSIONAL INSTALLATION ON ALL THEIR PRODUCTS



WARNING: When working on, under, or around any vehicle exercise caution. Please allow the vehicle's exhaust system to cool before removal, as exhaust system temperatures may cause severe burns. If working without a lift always consult vehicle manual for correct lifting specifications. Always wear safety glasses and ensure a safe work area. Serious injury or death could occur if safety measures are not followed.

ATTENTION: Always install any supplied band or U-bolt clamps to the proper torque specifications of 40-45 ft-lbs for band clamps and 30-35 ft-lbs for U-bolt clamps. Over tightening will result in the clamp breaking and will NOT be warranted by MagnaFlow.



Step 1. To remove the OEM exhaust system you will need to loosen the band clamp attaching the Tail Pipe Assembly to the Inlet Pipe Assembly. Next Unbolt the Inlet Pipe Assembly at the flange junction. Remove the O2 sensor. Disengage all welded hangers from the rubber insulators and remove the assembly. Do not discard the or damage the rubber insulators as they will be used to mount the new system.



Step 3. Next loosely attach the Tail Pipe Assembly to the Inlet Pipe Assembly using the supplied 2.50" clamps. Engage all welded hangers to the rubber insulators.



Step 4. Once a final position has been chosen for the new exhaust system, evenly tighten all clamps from front to rear using the torque specifications on page one of the instructions. Inspect all fasteners after 25-50 miles of operation and re-tighten if necessary.



Step 2. Begin installation of the new system by fastening the Inlet Pipe Assembly to the catalytic converter outlet using the OEM hardware. Attach the O2 sensor. Leave all clamps loose for the final adjustment of the complete system.