



INSTALLATION INSTRUCTIONS



2016 FORD MUSTANG GT 350 5.2L CARBON | PART NO. 19299

BILL OF MATERIALS:

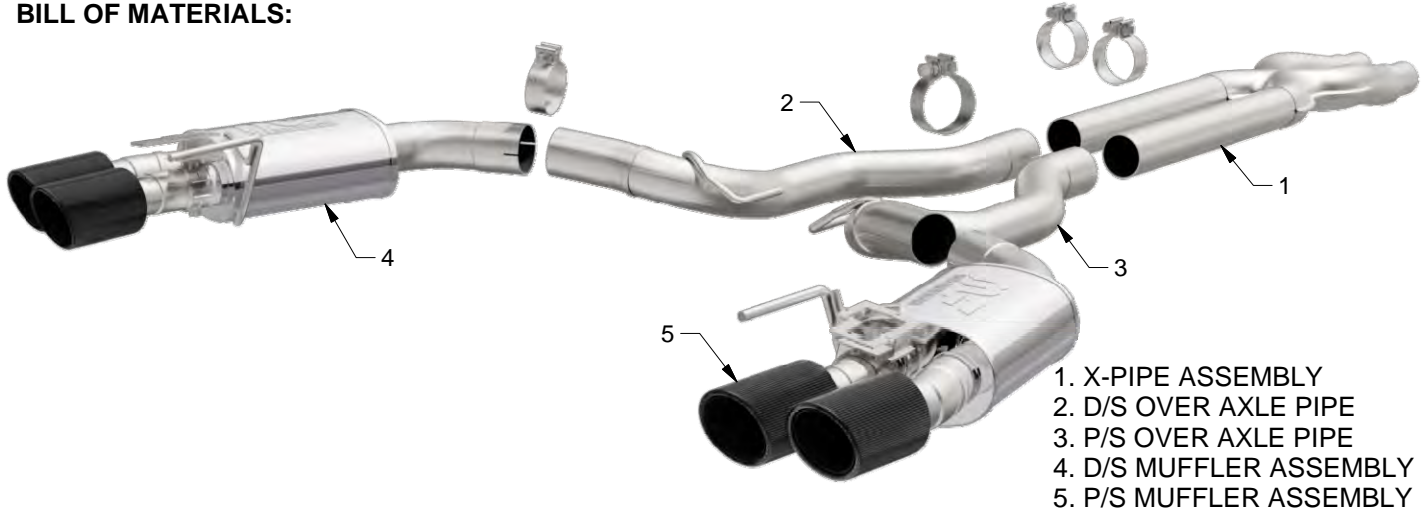

- 1. X-PIPE ASSEMBLY
- 2. D/S OVER AXLE PIPE
- 3. P/S OVER AXLE PIPE
- 4. D/S MUFFLER ASSEMBLY
- 5. P/S MUFFLER ASSEMBLY



WEAR SAFETY GLASSES



READ INSTRUCTIONS THOROUGHLY BEFORE INSTALLING PRODUCT

SHOP SUPPLIES:



SPRAY LUBRICANT

To ease removal of existing exhaust components (especially on older vehicles) spray penetrating lubricant on all fasteners and hangers/insulators that will be loosened or removed and let soak before disassembly.

HARDWARE KIT:

- 1. [4] 3.00" Clamp
- 2. [6] M5 Hex Bolts
- 3. [6] M5 Hex Nuts

MINIMUM REQUIRED TOOLS:



10mm, 13mm
15mm, Torx T-20



Hanger Tool
(Or Pry Bar)



Phillips, Flat Head

MAGNAFLOW RECOMMENDS PROFESSIONAL INSTALLATION ON ALL THEIR PRODUCTS



WARNING: When working on, under, or around any vehicle exercise caution. Please allow the vehicle's exhaust system to cool before removal, as exhaust system temperatures may cause severe burns. If working without a lift always consult vehicle manual for correct lifting specifications. Always wear safety glasses and ensure a safe work area. Serious injury or death could occur if safety measures are not followed.

ATTENTION: Always install any supplied band or V-band clamps to the proper torque specifications of 40-45 ft-lbs for band clamps and 70 in-lbs for V-band clamps. Over tightening will result in the clamp breaking and will NOT be warranted by MagnaFlow.

MAGNAFLOW 1901 Corporate Centre Dr., Oceanside CA 92056 | 1(800) 990-0905

Technical Support: 1(800) 959-9226 | Email: moreinfo@magnaflow.com

19299 1/30/18 REV 001

INSTALLATION INSTRUCTIONS



Step 1. To remove the OEM exhaust system you will first need to unplug the exhaust valve control motors located on the OEM muffer assembly.

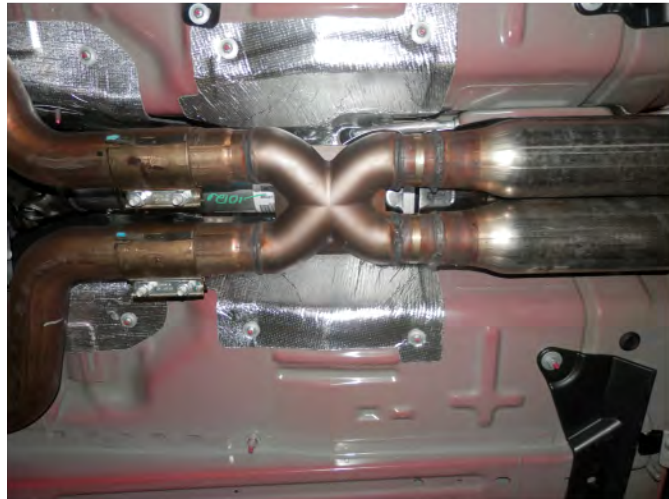

Step 2. Next loosen the clamps at the vehicles catalytic converter outlet pipes. Working from front to rear disengage all welded hangers from the rubber insulators. Retain all mounting hardware as it will be needed to mount your new MAGNAFLOW system.



Step 3. Once the OEM system has been removed undo three nuts attaching each exhaust valve motor to the valve and remove.



Step 4. Before installing your new exhaust system attach the OEM valve motors to each valve using the supplied M5 hardware. The alignment spring on the motor will need to be engaged into the keyway slot of the new valves.

INSTALLATION INSTRUCTIONS



Step 5. Install the X-Pipe Assembly to the OEM slip clamp. Engage the welded hangers to the rubber insulators. Leave all clamps loose for final adjustment of the system.



Step 6. Attach both Over Axle Pipes to the X-Pipe Assembly using the supplied clamps. Engage the welded hangers to the rubber insulators.



Step 7. Loosely install the Muffler Assemblies using the supplied clamp. Attach the welded hangers to the rubber insulators. Re-attach both electrical connectors to the exhaust valve motors.



Step 8. Once a final position has been chosen for the new exhaust system, evenly tighten all clamps from front to rear using the torque specifications on page one of the instructions. Inspect all fasteners after 25-50 miles of operation and re-tighten if necessary.