



# INSTALLATION INSTRUCTIONS



2014 Infiniti Q50 3.7L

PART NO. 15310

## BILL OF MATERIALS:

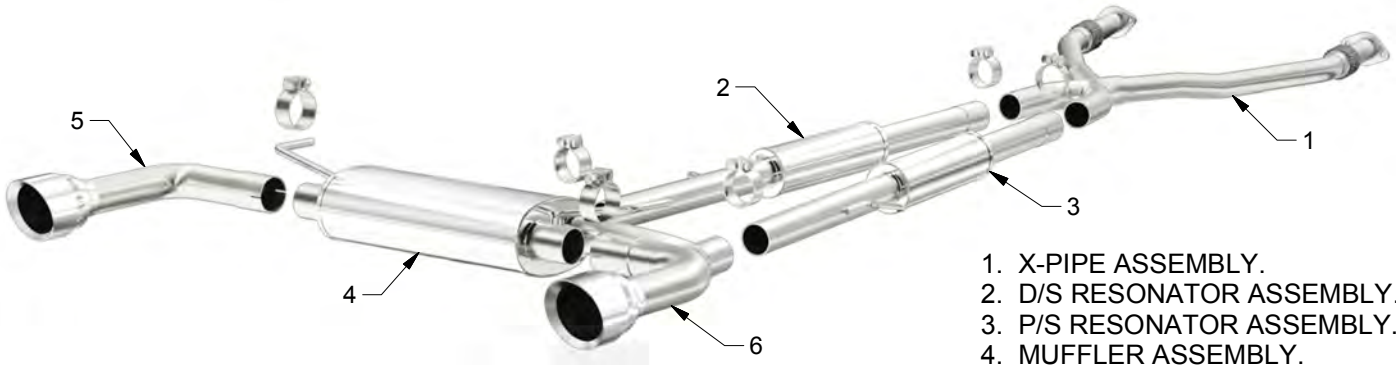

- 1. X-PIPE ASSEMBLY.
- 2. D/S RESONATOR ASSEMBLY.
- 3. P/S RESONATOR ASSEMBLY.
- 4. MUFFLER ASSEMBLY.
- 5. D/S TIP ASSEMBLY.
- 6. P/S TIP ASSEMBLY.



WEAR SAFETY GLASSES



READ INSTRUCTIONS THOROUGHLY BEFORE INSTALLING PRODUCT

## SHOP SUPPLIES:



SPRAY LUBRICANT

To ease removal of existing exhaust components (especially on older vehicles) spray penetrating lubricant on all fasteners and hangers/insulators that will be loosened or removed and let soak before disassembly.

## HARDWARE KIT:

- 1. [6] 2.50" Clamps

## MINIMUM REQUIRED TOOLS:



15mm



Hanger Tool (Or Pry Bar)

## MAGNAFLOW RECOMMENDS PROFESSIONAL INSTALLATION ON ALL THEIR PRODUCTS



**WARNING:** When working on, under, or around any vehicle exercise caution. Please allow the vehicle's exhaust system to cool before removal, as exhaust system temperatures may cause severe burns. If working without a lift always consult vehicle manual for correct lifting specifications. Always wear safety glasses and ensure a safe work area. Serious injury or death could occur if safety measures are not followed.

**ATTENTION:** Always install any supplied band or U-bolt clamps to the proper torque specifications of 40-45 ft-lbs for band clamps and 30-35 ft-lbs for U-bolt clamps. Over tightening will result in the clamp breaking and will NOT be warranted by MagnaFlow.

## INSTALLATION INSTRUCTIONS

**Step 1.** To remove the OEM exhaust system you will need to remove the cross brace. Next, unbolt both inlet flanges at the catalytic converter outlets. Working front to rear loosen the clamps holding the OEM system together. Disengage all welded hangers from the rubber isolators. The OEM system may now be removed. Be sure not to damage and retain all mounting hardware and hanger isolators as they will be reused to install your new MAGNAFLOW system.



**Step 2.** Install the new system by loosely attaching the new X-Pipe Assembly to the catalytic converter using the OEM hardware and by locating the welded hanger to the rubber isolator. Leave all clamps and fasteners loose for final adjustment of complete system.

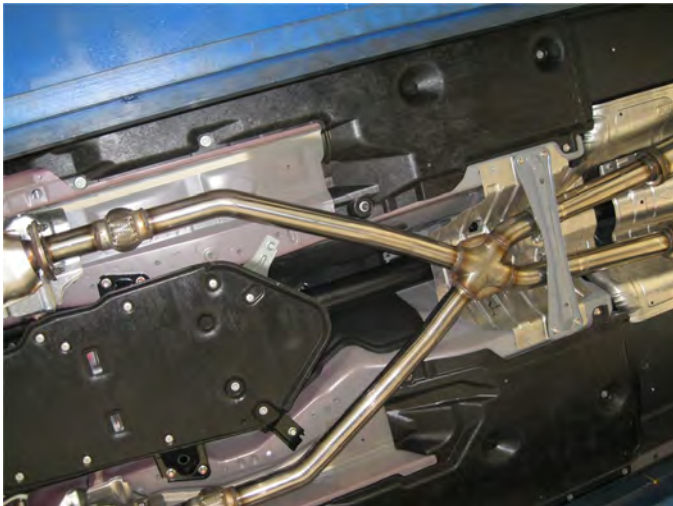

**Step 3.** Loosely attach the two Resonator Assemblies using the supplied 2.50" clamps and engaging the welded hangers to the rubber isolators..



**Step 4.** Loosely secure the Muffler Assembly and both Tip Assemblies in a similar fashion and reattach the cross brace.



**Step 5.** Once a final position has been chosen for the new exhaust system, evenly tighten all clamps from front to rear using the torque specifications on page one of the instructions. Inspect all fasteners after 25-50 miles of operation and re-tighten if necessary.

