

1992-2000 HONDA CIVICS - 4 CYL

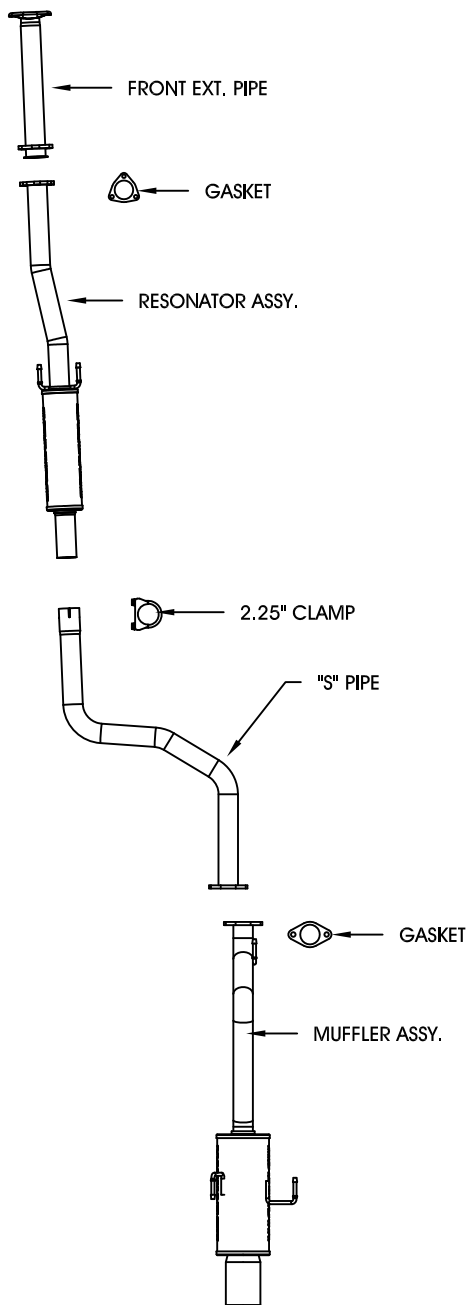

Warning: When working on under or around any vehicle exercise caution. Please allow vehicles exhaust system to cool before removal, as exhaust system temperatures may cause severe burns. If working without a lift, always consult vehicle manual for correct lifting specifications. Always wear safety glasses and ensure safe work area. Serious injury or death could occur if safety measures are not followed.

Step 1: (Carefully read all instructions before installation) Unbolt OEM muffler from extension pipe in front of rear control arm. Remove the muffler from the OEM rubber insulators. Do not damage the rubber insulators, as they will be re-used. Unbolt the front extension pipe from the catalytic converter. If the front extension pipe has a 2-bolt flange, do not discard the OEM spring/stud assemblies, as they will be re-used.

Step 2: Layout all parts of your new system according to the diagram shown. The front extension pipe is for certain vehicles that may require it. If the system will be mounted to the catalytic converter with a 2-bolt flange, you will need the front extension pipe. If the system will be mounted to a 3-bolt flange, the front extension pipe will not be needed.

Step 3: Starting at the catalytic converter, install the front extension pipe or resonator assembly, depending on your application. If your application requires the front extension pipe, you will need to re-use the OEM spring/stud assemblies. If your application does not require the front extension pipe, use the new hardware supplied in the kit. Leave all components loose until final fit and placement is correct. Working rearward, install the resonator assembly, the "S" extension pipe, and muffler. Be sure to check clearance around the rear control arm, and between the exhaust tip and rear bumper fascia. (MAGNAFLOW recommends at least 1/2" of clearance between the exhaust tip and rear bumper to avoid heat-related bodywork damage, or fire.)

Step 4: Evenly tighten all fasteners from front to rear to complete installation. Inspect all fasteners after 25-50 miles of operation, and re-tighten if necessary.

*MAGNAFLOW Performance Exhaust recommends professional installation on all their products

Technical support: 1-800-959-9226 ext. 4500