

1964-'66 FORD MUSTANG

Note: This system is designed to work with OEM-style exhaust manifolds, or tubular headers. Due to the various applications possible, some modification and welding is required for a proper fit and finish.

Warning: When working on, under, or around any vehicle exercise caution. Please allow the vehicle's exhaust system to cool before removal, as exhaust system temperatures may cause severe burns. If working without a lift, always consult vehicle manual for correct lifting specifications. Always wear safety glasses and ensure a safe work area. Serious injury or death could occur if safety measures are not followed.

Step 1: (Carefully read all instructions before installation) Disconnect the vehicle's battery before removal of the OEM exhaust system. This will prevent electrical accidents and will reset the computer if it applies to the vehicle. Remove the existing exhaust system from the exhaust manifolds / headers. Some systems may need to be cut for removal. Take notice of axle position and brake line position.

Step 2: Begin installation of the new system by fitting the new mufflers, tailpipes and Tru-X crossover assembly into place for a mock-up fitment, as shown to the left. This will help to determine where to drill the frame or floorboards for the muffler and tailpipe mounting brackets as shown in Figures 1 & 3, if the OEM mounting points will not work. Sheet metal screws are supplied to be used in place of the hex-head bolts if required. Use a 1/2" drill bit for the bolt/nut combo, or use a 5/16" drill bit for the tri-lobular sheet metal screws. You should now also be able to determine where to trim and or modify the inlet extension pipes if needed. With the system loosely installed, adjust the components for at least 1/2" clearance, including areas with moving parts (axles, driveshaft, etc.). Once a proper fit for the complete system has been achieved using the supplied clamps, the inlet pipes can be welded to the manifolds or headers. Once the tailpipe brackets are bolted in place as shown in Figure 3, they can be bent and welded to the tailpipes. The supplied turndown tips can be welded to the tailpipe to dump behind the bumper, or the tailpipe extensions can be used with or without the OEM tips to go through the bumper for an original look.

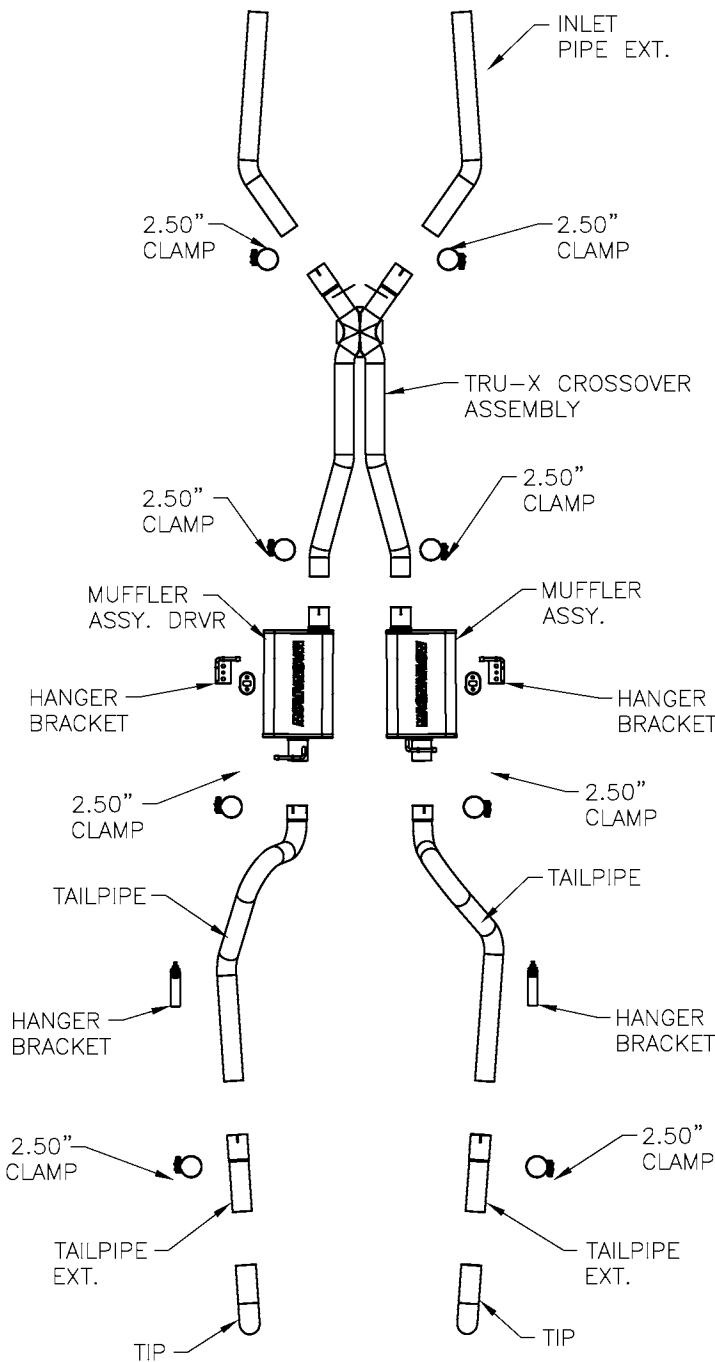

***MAGNAFLOW Performance Exhaust recommends professional installation on all their products**

Technical support: 1-800-959-9226 ext. 4500

MAGNAFLOW Performance Exhaust — 22961 Arroyo Vista — Rancho Santa Margarita, CA 92688

15815 10/25/13 REV 003

1964-'67 FORD MUSTANG



FIG. 1

Note: This system is designed to work with OEM-style exhaust manifolds, or tubular headers. Due to the various applications possible, some modification and welding is required for a proper fit and finish.

Warning: When working on, under, or around any vehicle exercise caution. Please allow the vehicle's exhaust system to cool before removal, as exhaust system temperatures may cause severe burns. If working without a lift, always consult vehicle manual for correct lifting specifications. Always wear safety glasses and ensure a safe work area. Serious injury or death could occur if safety measures are not followed.

Step 3: Once a final position has been chosen for the new system, evenly tighten all fasteners from front to rear. The supplied band clamps must be VERY tight to properly align the pipes and prevent leaks (Approximately 40ft-lbs). Inspect all fasteners after 25-50 miles of operation and retighten if necessary.

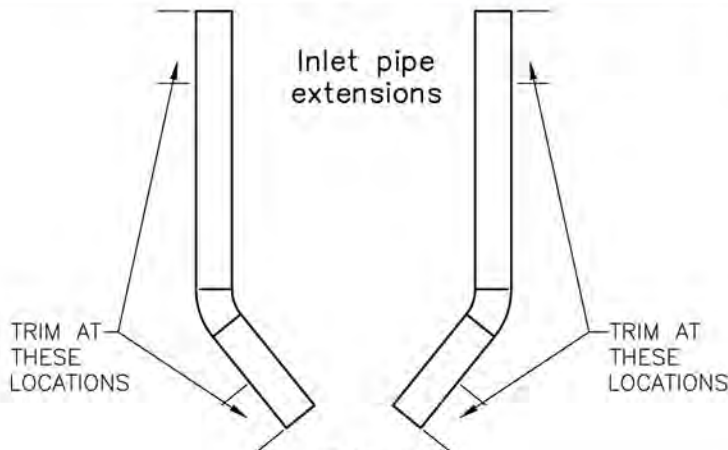

FIG. 2

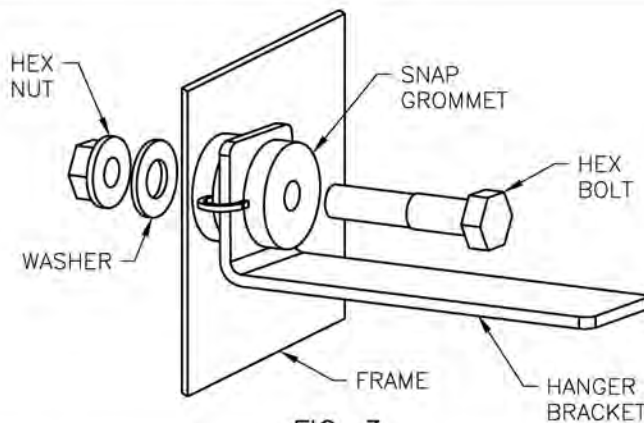

FIG. 3

*MAGNAFLOW Performance Exhaust recommends professional installation on all their products

Technical support: 1-800-959-9226 ext. 4500

MAGNAFLOW Performance Exhaust - 22961 Arroyo Vista - Rancho Santa Margarita, CA 92688

15815 10/25/13 REV 003