



INSTALLATION INSTRUCTIONS



2010-15 CHEVROLET CAMARO 3.6L | PART NO. 15353

BILL OF MATERIALS:

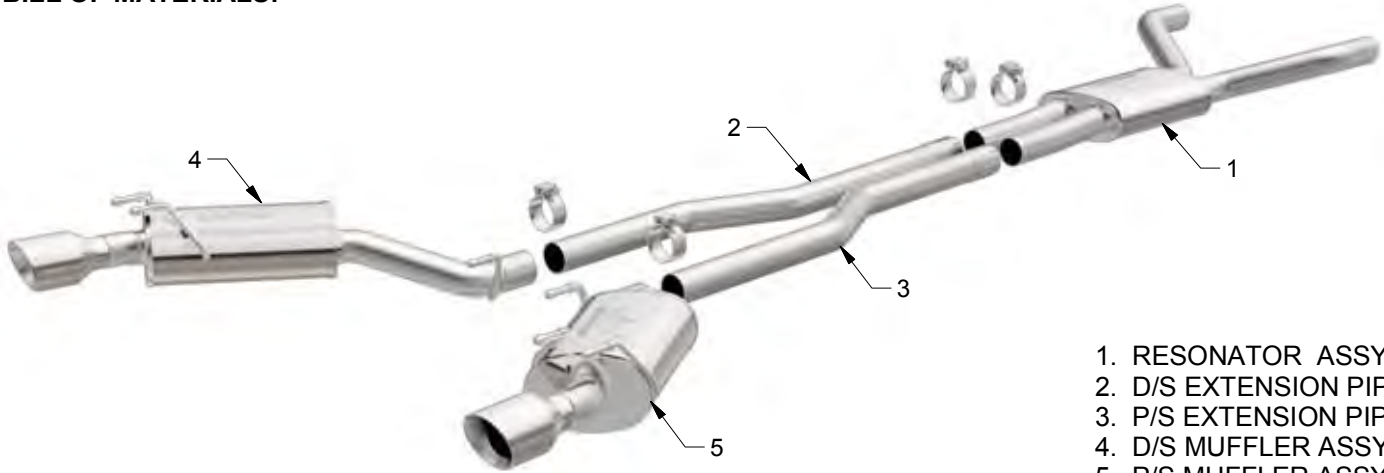

- 1. RESONATOR ASSY.
- 2. D/S EXTENSION PIPE
- 3. P/S EXTENSION PIPE
- 4. D/S MUFFLER ASSY
- 5. P/S MUFFLER ASSY



WEAR SAFETY GLASSES



READ INSTRUCTIONS THOROUGHLY BEFORE INSTALLING PRODUCT



SPRAY LUBRICANT

To ease removal of existing exhaust components (especially on older vehicles) spray penetrating lubricant on all fasteners and hangers/insulators that will be loosened or removed and let soak before disassembly.

SHOP SUPPLIES:

HARDWARE KIT:

- 1. [4] 2.50" Clamp

MINIMUM REQUIRED TOOLS:



15mm
13mm



Hanger Tool
(Or Pry Bar)

MAGNAFLOW RECOMMENDS PROFESSIONAL INSTALLATION ON ALL THEIR PRODUCTS



WARNING: When working on, under, or around any vehicle exercise caution. Please allow the vehicle's exhaust system to cool before removal, as exhaust system temperatures may cause severe burns. If working without a lift always consult vehicle manual for correct lifting specifications. Always wear safety glasses and ensure a safe work area. Serious injury or death could occur if safety measures are not followed.

ATTENTION: Always install any supplied band or U-bolt clamps to the proper torque specifications of 40-45 ft-lbs for band clamps and 30-35 ft-lbs for U-bolt clamps. Over tightening will result in the clamp breaking and will NOT be warranted by MagnaFlow.

X INSTALLATION INSTRUCTIONS

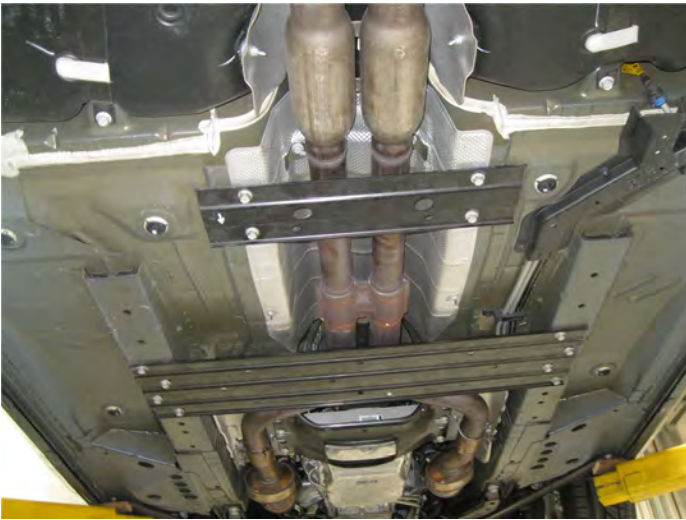

Step 1. Begin by removing the two front crossmembers and the two rear chassis stiffeners by the muffler inlets. This will allow access to the exhaust system.



Step 2. To remove the OEM exhaust loosen the two bolt clamps located behind the catalytic converters. Working rearward disengage the rubber insulators from the welded hangers, retain clamps and rubber insulators as they will be used to install the new system. Remove complete system.



INSTALLATION INSTRUCTIONS

Step 3. Begin installation of the new system by loosely attaching the Resonator Assembly to the catalytic converter outlets using the OEM clamps.



Step 4. Next, attach the Driver and Passenger Side Extension Pipes (as shown) to the Resonator Assembly using the supplied 2.50" clamps.



Step 5. Finish by attaching the Muffler Assemblies to the extension pipes using the supplied 2.50" clamps and fitting the hangers into the rubber insulators. Replace crossmembers and chassis stiffeners.



Step 6. Once a final position has been chosen for the new exhaust system, evenly tighten all clamps from front to rear using the torque specifications on page one of the instructions. Inspect all fasteners after 25-50 miles of operation and re-tighten if necessary.