



INSTALLATION INSTRUCTIONS



2014-2015 JEEP GRAND CHEROKEE 3.6L | PART NO. 19193

BILL OF MATERIALS:

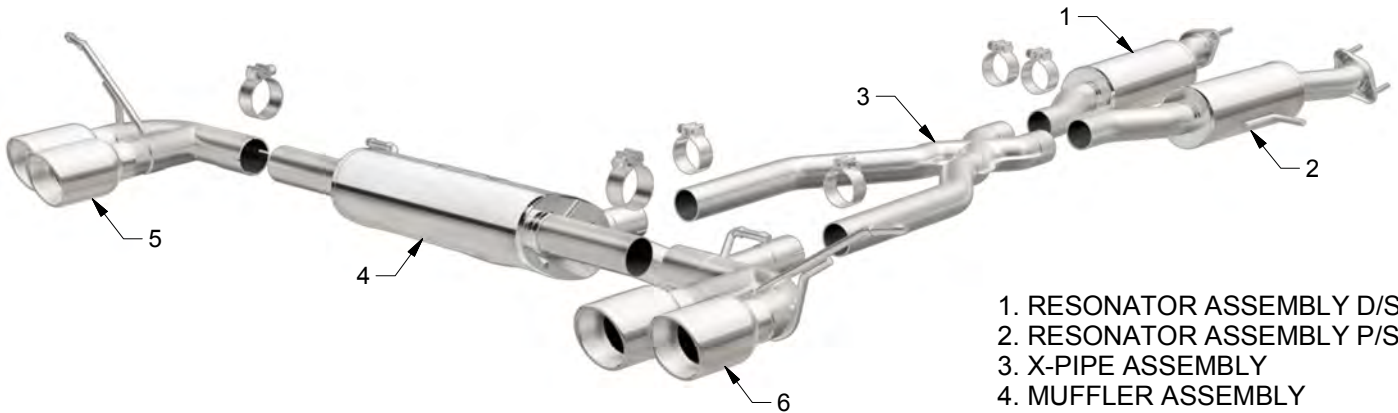

- 1. RESONATOR ASSEMBLY D/S
- 2. RESONATOR ASSEMBLY P/S
- 3. X-PIPE ASSEMBLY
- 4. MUFFLER ASSEMBLY
- 5. TAILPIPE ASSEMBLY D/S
- 6. TAILPIPE ASSEMBLY P/S



WEAR SAFETY GLASSES



READ INSTRUCTIONS THOROUGHLY BEFORE INSTALLING PRODUCT

SHOP SUPPLIES:



SPRAY LUBRICANT

To ease removal of existing exhaust components (especially on older vehicles) spray penetrating lubricant on all fasteners and hangers/insulators that will be loosened or removed and let soak before disassembly.

HARDWARE KIT:

- 1.[6] 2.50" Clamp
- 2.[4] 10mm Bolts

MINIMUM REQUIRED TOOLS:



15mm



Hanger Tool (Or Pry Bar)

MAGNAFLOW RECOMMENDS PROFESSIONAL INSTALLATION ON ALL THEIR PRODUCTS



WARNING: When working on, under, or around any vehicle exercise caution. Please allow the vehicle's exhaust system to cool before removal, as exhaust system temperatures may cause severe burns. If working without a lift always consult vehicle manual for correct lifting specifications. Always wear safety glasses and ensure a safe work area. Serious injury or death could occur if safety measures are not followed.

ATTENTION: Always install any supplied band or U-bolt clamps to the proper torque specifications of 40-45 ft-lbs for band clamps and 30-35 ft-lbs for U-bolt clamps. Over tightening will result in the clamp breaking and will NOT be warranted by MagnaFlow.

X INSTALLATION INSTRUCTIONS



Step 1. Begin removal of the OEM exhaust system by unfastening the spring loaded two bolt flanges located in front of the factory resonator.



Step 2. Working rearward disengage the hangers from the rubber insulators and un-fasten the two bolt flange at the driver side rear muffler and remove the OEM exhaust.



Step 3. Begin installation of your new MAGNAFLOW system by attaching the Driver and Passenger side Resonator Assemblies at the two bolt flange locations using the supplied 10MM bolts and the OEM nuts and springs and fitting the hangers into the rubber insulators. Keep all fasteners and clamps loose until final adjustment.



Step 4. Next use the supplied 2.5" clamps to attach the X-Pipe to the Resonator Assemblies.



Step 5. Finish by attaching the Muffler Assembly to the Mid Pipe and the Tail Pipe Assemblies to the Muffler using the supplied 2.5" clamps. Fit hangers into rubber insulators.



Step 6. Once a final position has been chosen for the new exhaust system, evenly tighten all clamps from front to rear using the torque specifications on page one of the instructions. Inspect all fasteners after 25-50 miles of operation and re-tighten if necessary.