



INSTALLATION INSTRUCTIONS



2017 FORD F-150 RAPTOR 3.5L | PART NO. 19346

BILL OF MATERIALS:

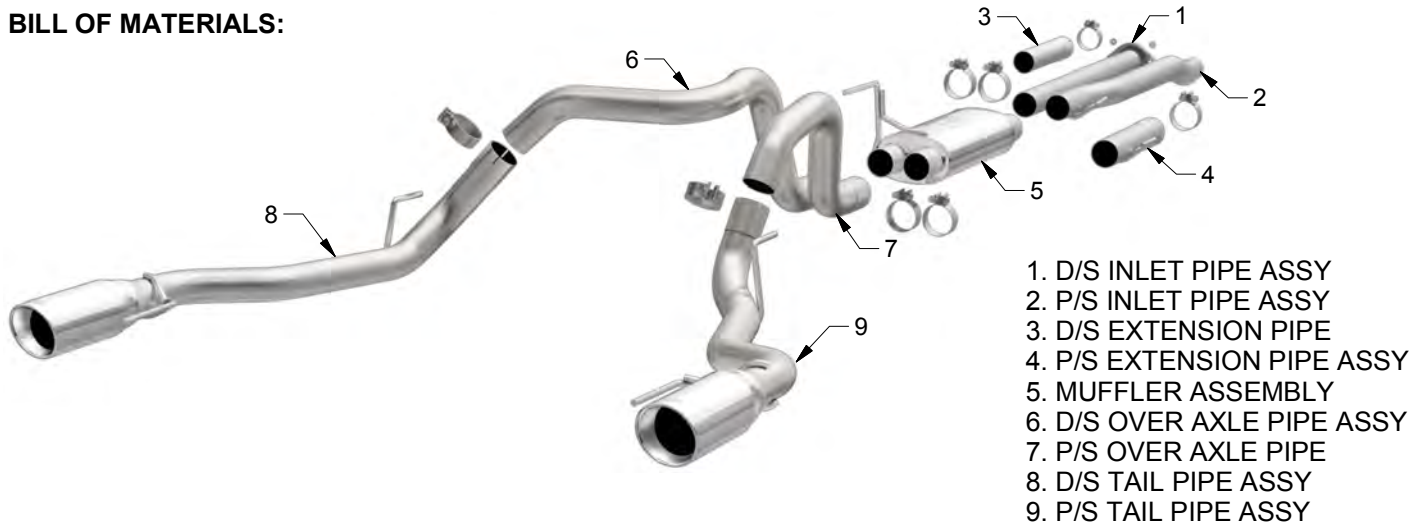

WEAR SAFETY GLASSES



READ INSTRUCTIONS THOROUGHLY BEFORE INSTALLING PRODUCT

SHOP SUPPLIES:



SPRAY LUBRICANT

To ease removal of existing exhaust components (especially on older vehicles) spray penetrating lubricant on all fasteners and hangers/insulators that will be loosened or removed and let soak before disassembly.

HARDWARE KIT:

- 1.[8] 3.00" Clamp
- 2.[2] Nut Hex M10-1.50

MINIMUM REQUIRED TOOLS:



12mm, 15mm



Hanger Tool (Or Pry Bar)

MAGNAFLOW RECOMMENDS PROFESSIONAL INSTALLATION ON ALL THEIR PRODUCTS



WARNING: When working on, under, or around any vehicle exercise caution. Please allow the vehicle's exhaust system to cool before removal, as exhaust system temperatures may cause severe burns. If working without a lift always consult vehicle manual for correct lifting specifications. Always wear safety glasses and ensure a safe work area. Serious injury or death could occur if safety measures are not followed.

ATTENTION: Always install any supplied band or U-bolt clamps to the proper torque specifications of 40-45 ft-lbs for band clamps and 30-35 ft-lbs for U-bolt clamps. Over tightening will result in the clamp breaking and will NOT be warranted by MagnaFlow.

X INSTALLATION INSTRUCTIONS



Step 1. Begin removal of the OEM exhaust system by loosening the band clamps attaching the tail pipe assemblies to the over axle pipes. Disengage all welded hangers from the rubber insulators and remove both tail pipes. Retain all mounting hardware as it will be used to install your new system.



Step 2. Next loosen both band clamps attaching the rear muffler subassembly to the inlet muffler assembly. Disengage all welded hangers from the rubber insulators. The muffler subassembly may now be removed.



Step 3. Finally remove the OEM inlet muffler assembly by unbolting the inlet at the driver side flange junction and loosening the band clamp on the passenger side inlet pipe. Remove the inlet muffler assembly. You are now ready to install your new MAGNAFLOW exhaust system.



Step 4. - NOTICE - this exhaust kit works with both the SuperCrew and SuperCab models. The SuperCrew has additional parts. Begin the installation by slipping the inlet of the P/S Inlet Pipe Assembly into the OEM band clamp. On the SuperCab model engage the welded hanger into the rubber insulator. Next bolt the D/S Inlet Pipe assembly to the OEM flange junction using the supplied nuts. All clamps and fasteners are to remain loose until final installation.

INSTALLATION INSTRUCTIONS



Step 5. FOR THE SUPERCREW ONLY, install both extension pipes into the resonator outlets and engage the hanger into the rubber insulator.



Step 7. Loosely attach both Over Axle Pipes to the Muffler Assembly outlets using the supplied clamps.



Step 6. Install the Muffler Assembly by attaching the inlet nipples to the outlets of both Inlet Pipe Assemblies(SuperCab) or Extension Pipes (SuperCrew). Loosely secure using the supplied clamps. Engage the welded hanger to the rubber insulator.



Step 8. Finish by loosely attaching both Tail Pipe Assemblies to the Over Axles Pipes using the supplied clamps. Engage the welded hangers to the rubber insulators.



Step 9. Once a final position has been chosen for the new exhaust system, evenly tighten all clamps from front to rear using the torque specifications on page one of the instructions. Inspect all fasteners after 25-50 miles of operation and re-tighten if necessary.