



INSTALLATION INSTRUCTIONS



DODGE DURANGO 6.4L

PART NO. 19628

BILL OF MATERIALS:

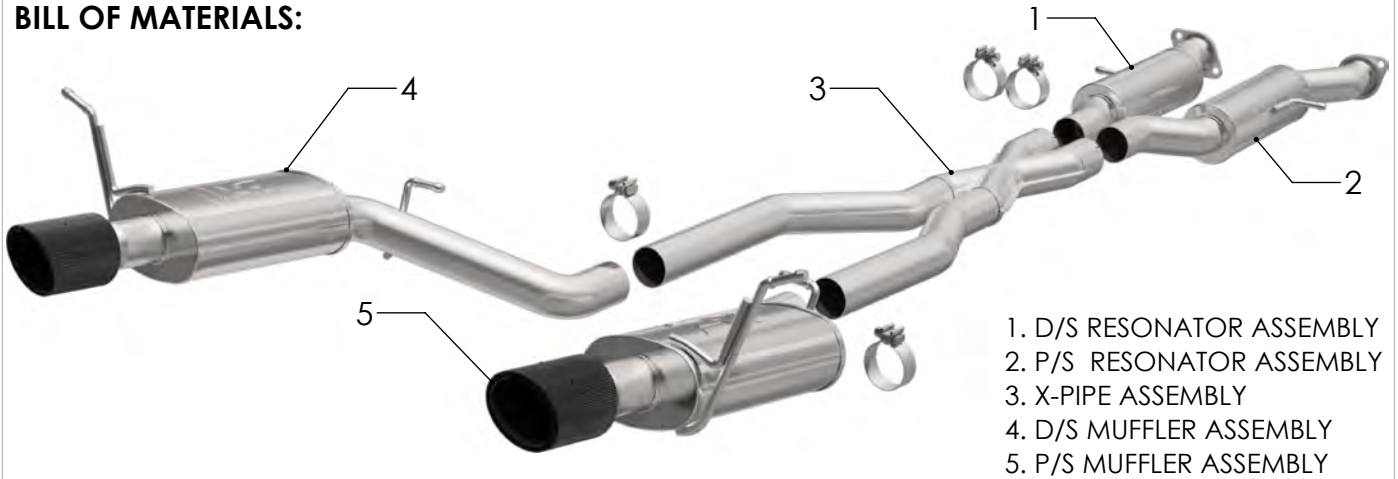

WEAR SAFETY GLASSES



READ INSTRUCTIONS THOROUGHLY BEFORE INSTALLING PRODUCT



SPRAY LUBRICANT

To ease removal of existing exhaust components (especially on older vehicles) spray penetrating lubricant on all fasteners and hangers/insulators that will be loosened or removed and let soak before disassembly.

HARDWARE KIT:

- 1.[4] 3.00" Band Clamp
- 2.[4] M10 Bolts
- 3.(4) M10 Flat Washers

MINIMUM REQUIRED TOOLS:



13mm, 15 mm



Hanger Tool (Or Pry Bar)

MAGNAFLOW RECOMMENDS PROFESSIONAL INSTALLATION ON ALL THEIR PRODUCTS



WARNING: When working on, under, or around any vehicle exercise caution. Please allow the vehicle's exhaust system to cool before removal, as exhaust system temperatures may cause severe burns. If working without a lift always consult vehicle manual for correct lifting specifications. Always wear safety glasses and ensure a safe work area. Serious injury or death could occur if safety measures are not followed.

ATTENTION: Always install any supplied band or U-bolt clamps to the proper torque specifications of 40-45 ft-lb for band clamps and 30-35 ft-lb for U-bolt clamps. Over tightening will result in the clamps breaking and will NOT be warranted by MagnaFlow.

MAGNAFLOW: 1901 Corporate Centre Dr - Oceanside, CA 92056 | 1(800)990-0905

Technical Support: 1(800) 959-9226 | Email: moreinfo@magnaflow.com

INSTALLATION INSTRUCTIONS



Step 1. Remove the OE exhaust system by first loosening the spring bolt fasteners from the flanges located at the front of the underbody Resonator. Next working front to rear extract the hangers from the rubber insulators and remove the complete exhaust system. Retain insulators as they will be used to install the new system.

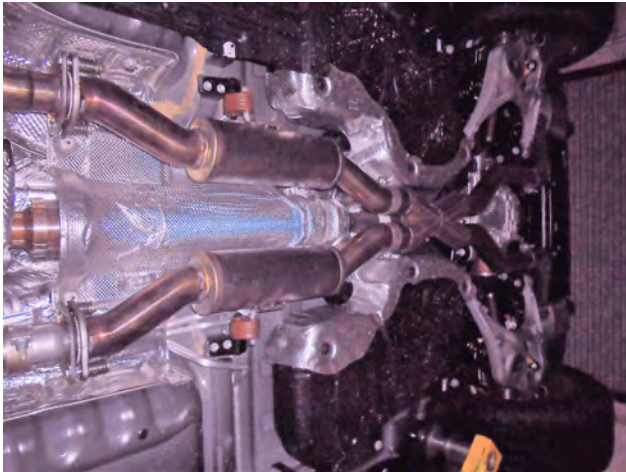

Step 2. Begin installation of the new system by loosely attaching the Driver and Passenger side Resonator assemblies the the two bolt flanges using the OE spring bolt fasteners and fitting the hangers into the rubber insulators. Leave all clamps and fasteners loose until final adjustment.

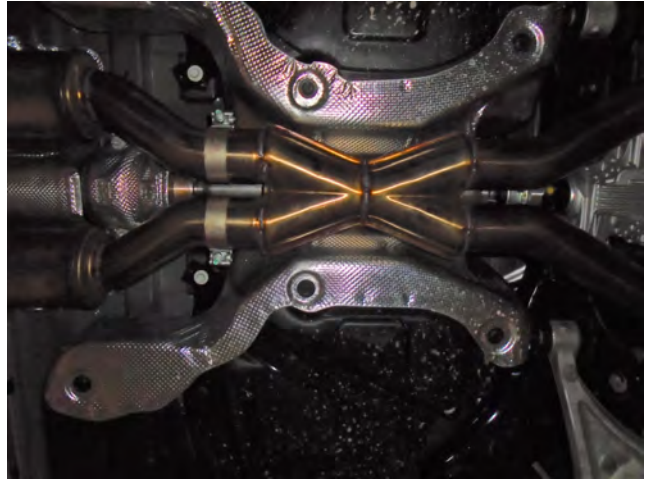

Step 3. Next attach the X-Pipe Assembly to the Resonators using the supplied 3.00" clamps



Step 4. Finish by installing the Passenger and Driver Side Muffler Assemblies using the supplied 3.00" clamps and fitting the hangers into the rubber insulators.



Step 5. Once a final position has been chosen for the new exhaust system, evenly tighten all clamps and fasteners using the torque specifications on page one of the instructions. Inspect all fasteners after 25-50 miles of operation and re-tighten as necessary.