



INSTALLATION INSTRUCTIONS



FORD RANGER BLACK

PART NO. 19634

BILL OF MATERIALS:

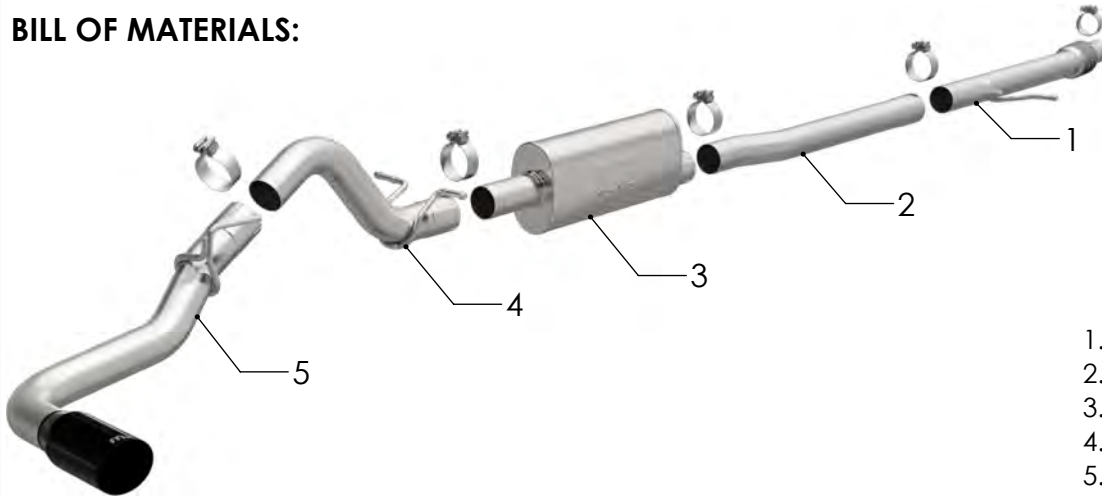

- 1. INLET PIPE ASSY
- 2. EXTENSION PIPE ASSY
- 3. MUFFLER ASSY
- 4. OVER AXLE ASSY
- 5. TAILPIPE ASSY



WEAR SAFETY GLASSES



READ INSTRUCTIONS THOROUGHLY BEFORE INSTALLING PRODUCT



SPRAY LUBRICANT

To ease removal of existing exhaust components (especially on older vehicles) spray penetrating lubricant on all fasteners and hangers/insulators that will be loosened or removed and let soak before disassembly.

HARDWARE KIT:

- 1. [4] 3.00" Clamp
- 2. [1] 2.50" Clamp

MINIMUM REQUIRED TOOLS:



13mm, 15 mm



Hanger Tool (Or Pry Bar)

MAGNAFLOW RECOMMENDS PROFESSIONAL INSTALLATION ON ALL THEIR PRODUCTS



WARNING: When working on, under, or around any vehicle exercise caution. Please allow the vehicle's exhaust system to cool before removal, as exhaust system temperatures may cause severe burns. If working without a lift always consult vehicle manual for correct lifting specifications. Always wear safety glasses and ensure a safe work area. Serious injury or death could occur if safety measures are not followed.

ATTENTION: Always install any supplied band or U-bolt clamps to the proper torque specifications of 40-45 ft-lb for band clamps and 30-35 ft-lb for U-bolt clamps. Over tightening will result in the clamps breaking and will NOT be warranted by MagnaFlow.

MAGNAFLOW: 1901 Corporate Centre Dr - Oceanside, CA 92056 | 1(800)990-0905

Technical Support: 1(800) 959-9226 | Email: moreinfo@magnaflow.com

INSTALLATION INSTRUCTIONS

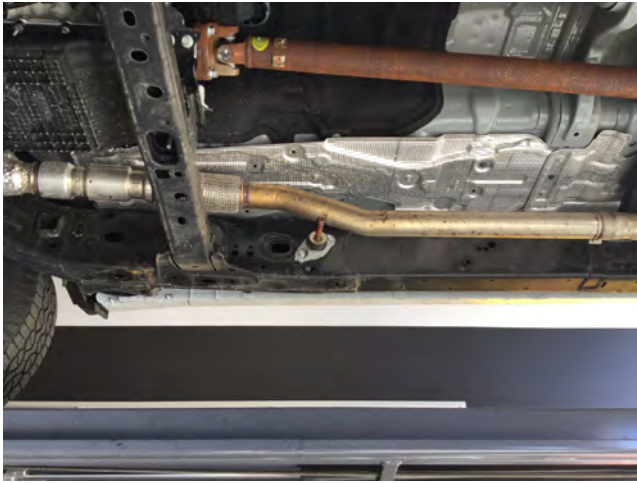

Step 1. To remove the OE exhaust system begin by loosening the clamps at the outlet of the catalytic converter and the inlet of the muffler. With the exhaust supported disengage the welded hangers from the rubber insulators and remove the system. Do not damage or discard the rubber insulators as they will be used to install the MagnaFlow system.



Step 2. Begin installation by attaching the Inlet Pipe Assembly to the outlet of the catalytic converter using the supplied 2.50" clamp and fitting the welded hanger into the rubber insulator (Leave all clamps and fasteners loose for final adjustment of the complete system.)



Step 3. Next, attach the Extension Pipe Assembly and the Muffler using the supplied 3.00" clamps and engaging the hanger into the rubber insulator.

INSTALLATION INSTRUCTIONS



Step 4. Attach the Over Axle Pipe to the Muffler Assembly using the supplied 3.00" clamp and engaging the welded hangers .



Step 5. Finish the installation by attaching the Tail Pipe Assembly to the Over Axle Pipes using the supplied 2.50" clamps and fitting the hanger into the rubber insulator.



Step 6. Once a final position has been chosen for the new exhaust system, evenly tighten all clamps from front to rear using the torque specifications on page one of the instructions. Inspect all fasteners after 25-50 miles of operation and re-tighten if necessary.