



INSTALLATION INSTRUCTIONS



2023+ Sequoia Overland

PART NO. 19625

BILL OF MATERIALS:

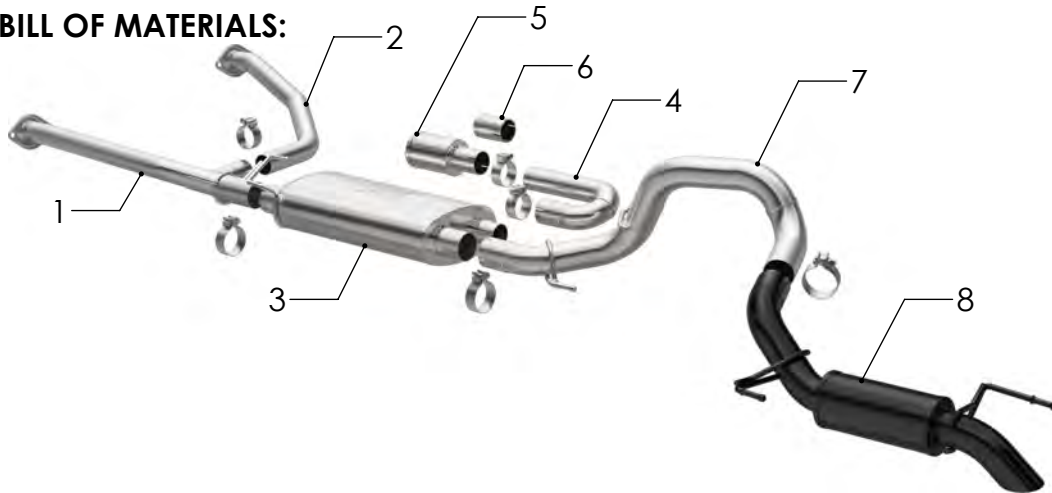

- 1. Inlet D/S Assy.
- 2. Inlet P/S Assy.
- 3. Muffler Assy.
- 4. Midpipe Assy.
- 5. NDT Resonator
- 6. Pipe Cap
- 7. Overaxle Assy.
- 8. Tailpipe Assy.



WEAR SAFETY GLASSES



READ INSTRUCTIONS THOROUGHLY BEFORE INSTALLING PRODUCT



SPRAY LUBRICANT

To ease removal of existing exhaust components (especially on older vehicles) spray penetrating lubricant on all fasteners and hangers/insulators that will be loosened or removed and let soak before disassembly.

HARDWARE KIT:

- 1. [3] 2.50" Clamp
- 2. [3] 3.00" Clamp
- 3. [1] MF Block Off Pipe

MINIMUM REQUIRED TOOLS:



13,15 mm



Hanger Tool (Or Pry Bar)

MAGNAFLOW RECOMMENDS PROFESSIONAL INSTALLATION ON ALL THEIR PRODUCTS



WARNING: When working on, under, or around any vehicle exercise caution. Please allow the vehicle's exhaust system to cool before removal, as exhaust system temperatures may cause severe burns. If working without a lift always consult vehicle manual for correct lifting specifications. Always wear safety glasses and ensure a safe work area. Serious injury or death could occur if safety measures are not followed.

ATTENTION: Always install any supplied band or U-bolt clamps to the proper torque specifications of 40-45 ft-lb for band clamps and 30-35 ft-lb for U-bolt clamps. Over tightening will result in the clamps breaking and will NOT be warranted by MagnaFlow.

MAGNAFLOW: 1901 Corporate Centre Dr - Oceanside, CA 92056 | 1(800)990-0905

Technical Support: 1(800) 959-9226 | Email: moreinfo@magnaflow.com

INSTALLATION INSTRUCTIONS



Step 1. To remove the OE exhaust system, loosen fasteners at the inlet flanges (2) where they connect to the catalytic converters. Working front to rear disengage the hangers from the rubber isolators, remove the remaining fasteners at flange junctions, and drop the system. (Retain the inlet fasteners, gaskets, and rubber isolators, as they will be used to install your new system.



Step 2. Begin installation of the new MagnaFlow system by attaching the Passenger Side inlet first, followed by the Driver Side/Y-Pipe Assembly. Use factory hardware to attach the flanges together, and a provided 2.50" TORCA clamp to attach the passenger side inlet to the Y-Pipe.

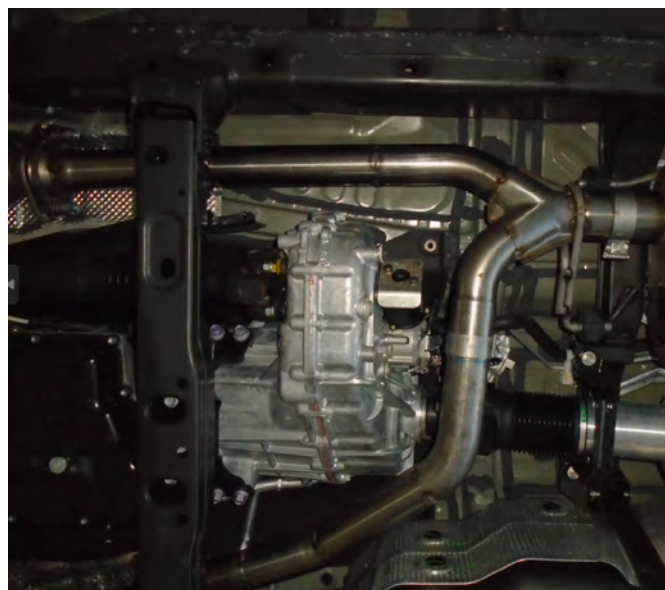

Step 3. Next, slide the Muffler Assembly into the outlet of the Y-Pipe, and fasten the hanger to the rubber, factory, isolators. Loosely tighten a 3.00" TORCA clamp to hold the muffler in place.

INSTALLATION INSTRUCTIONS



Step 4. Next, install the Over-Axle Pipe. Slide a 3" TORCA clamp on the muffer outlet and loosely tighten to hold in place. Also attach the hangers to the factory isolators.

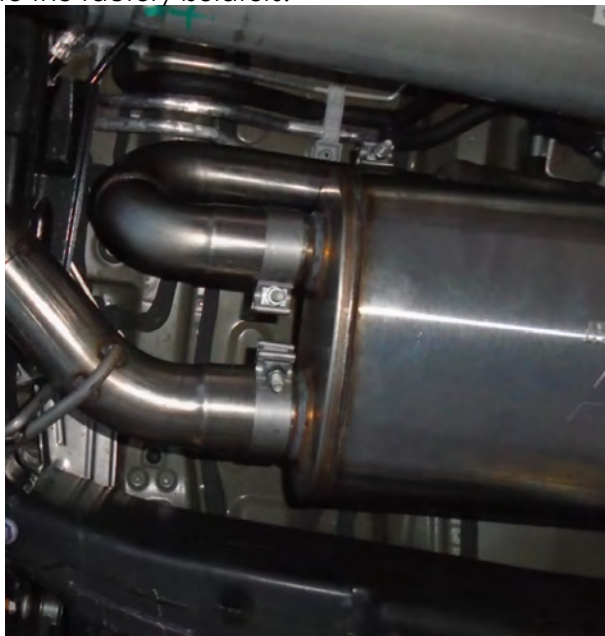

Step 5. Install the Helmholtz J-Pipe using a 2.50" TORCA Clamp, and be sure to cap the end using the provided MF label Cap, also with a 2.50" TORCA.



Step 6. Lastly, install the tailpipe resonator assembly utilizing a 3.00" TORCA clamp. From Rear to Front, tighten the entire assembly. Be sure to re-tighten after the first 100 miles after all components have been properly heat cycled.