



INSTALLATION INSTRUCTIONS



2014-2016 RAM 1500 3.0L DIESEL | PART NO. 19359

BILL OF MATERIALS:

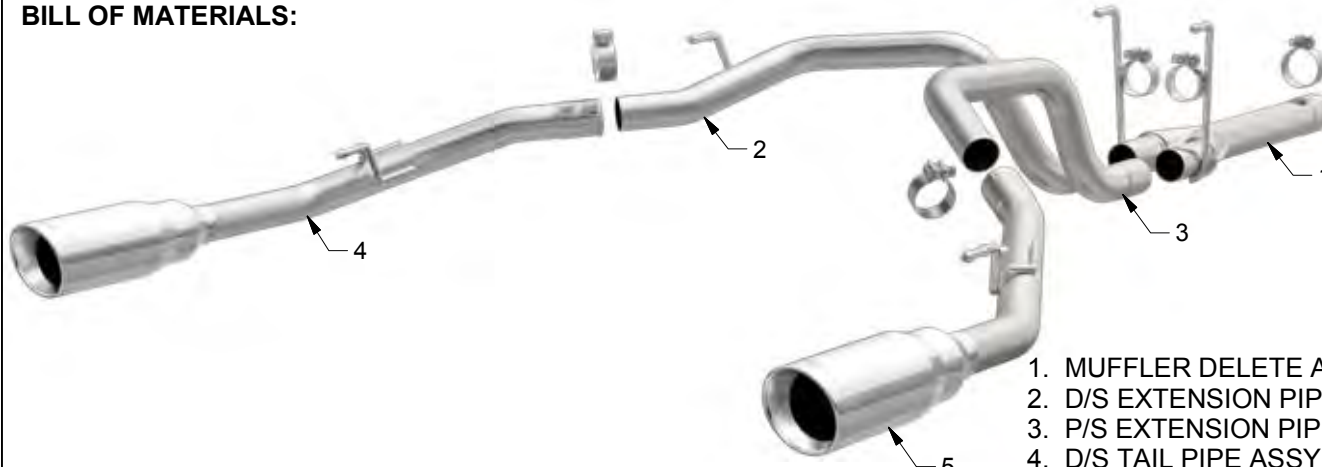

- 1. MUFFLER DELETE ASSY
- 2. D/S EXTENSION PIPE ASSY
- 3. P/S EXTENSION PIPE ASSY
- 4. D/S TAIL PIPE ASSY
- 5. P/S TAIL PIPE ASSY



WEAR SAFETY GLASSES



READ INSTRUCTIONS THOROUGHLY BEFORE INSTALLING PRODUCT

SHOP SUPPLIES:



SPRAY LUBRICANT

To ease removal of existing exhaust components (especially on older vehicles) spray penetrating lubricant on all fasteners and hangers/insulators that will be loosened or removed and let soak before disassembly.

HARDWARE KIT:

- 1. [4] 2.50" Clamp
- 2. [1] 3.00" Clamp

MINIMUM REQUIRED TOOLS:



15mm
13mm



Hanger Tool
(Or Pry Bar)

MAGNAFLOW RECOMMENDS PROFESSIONAL INSTALLATION ON ALL THEIR PRODUCTS



WARNING: When working on, under, or around any vehicle exercise caution. Please allow the vehicle's exhaust system to cool before removal, as exhaust system temperatures may cause severe burns. If working without a lift always consult vehicle manual for correct lifting specifications. Always wear safety glasses and ensure a safe work area. Serious injury or death could occur if safety measures are not followed.

ATTENTION: Always install any supplied band or U-bolt clamps to the proper torque specifications of 40-45 ft-lbs for band clamps and 30-35 ft-lbs for U-bolt clamps. Over tightening will result in the clamp breaking and will NOT be warranted by MagnaFlow.

INSTALLATION INSTRUCTIONS



Step 1. Begin removal of the OEM system by loosening the clamp at the front of the muffler and disengaging the hangers from the rubber insulators. Working rearward finish removing the system. Do not damage or discard the rubber insulators as they will be re-used to mount the new system.



NOTE: The muffler pictured is not applicable for your MAGNAFLOW system.

Step 2. Begin installation of the new system by attaching the Muffler Delete Pipe Assembly to the factory outlet using the supplied 3.00" clamp and fit the hangers into the rubber insulators. Ensure that the indexing slot on the inlet is properly engaged with the pin. Leave all clamps loose until final adjustment.



Step 3. Next Install the Driver and Passenger side Extension Pipe Assemblies using the supplied 2.50" clamps and fitting the hangers into the rubber insulators.

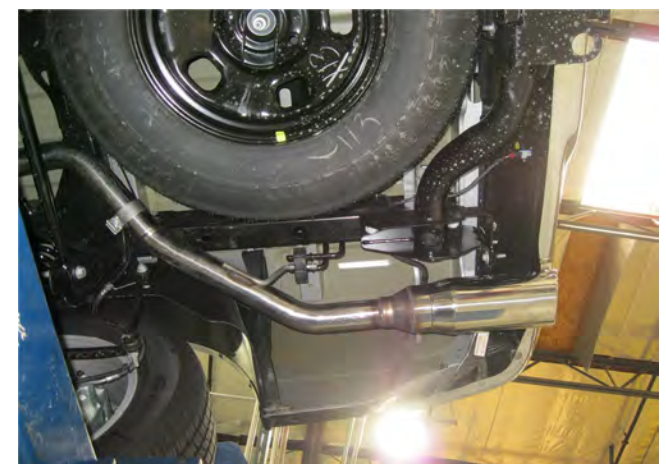

Step 4. Complete the installation by fastening the Driver and Passenger side Tailpipe Assemblies to the Extension Pipe Assemblies with the supplied 2.50" clamps and fit the hangers into the insulators.



Step 5. Once a final position has been chosen for the new exhaust system, evenly tighten all clamps from front to rear using the torque specifications on page one of the instructions. Inspect all fasteners after 25-50 miles of operation and re-tighten if necessary.