



INSTALLATION INSTRUCTIONS



2010-2016 AUDI S4 3.0L | PART NO. 15599

BILL OF MATERIALS:

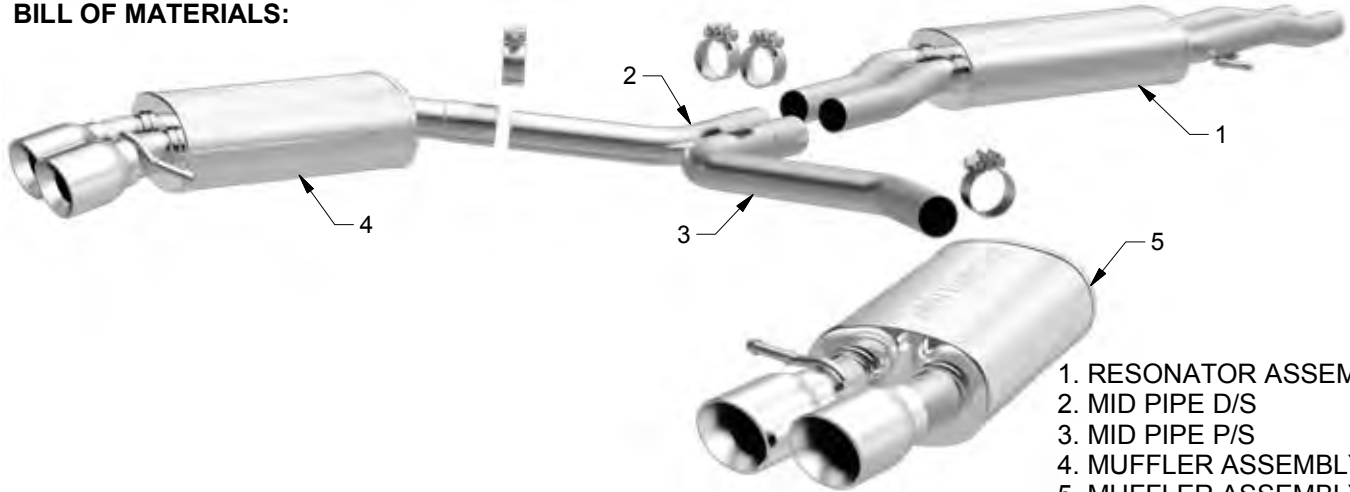

- 1. RESONATOR ASSEMBLY
- 2. MID PIPE D/S
- 3. MID PIPE P/S
- 4. MUFFLER ASSEMBLY D/S
- 5. MUFFLER ASSEMBLY P/S



WEAR SAFETY GLASSES



READ INSTRUCTIONS THOROUGHLY BEFORE INSTALLING PRODUCT

SHOP SUPPLIES:



SPRAY LUBRICANT

To ease removal of existing exhaust components (especially on older vehicles) spray penetrating lubricant on all fasteners and hangers/insulators that will be loosened or removed and let soak before disassembly.

HARDWARE KIT:

- 1.[4] 2.25" Clamp

MINIMUM REQUIRED TOOLS:



15mm, 19mm



Hanger Tool (Or Pry Bar)

MAGNAFLOW RECOMMENDS PROFESSIONAL INSTALLATION ON ALL THEIR PRODUCTS



WARNING: When working on, under, or around any vehicle exercise caution. Please allow the vehicle's exhaust system to cool before removal, as exhaust system temperatures may cause severe burns. If working without a lift always consult vehicle manual for correct lifting specifications. Always wear safety glasses and ensure a safe work area. Serious injury or death could occur if safety measures are not followed.

ATTENTION: Always install any supplied band or U-bolt clamps to the proper torque specifications of 40-45 ft-lbs for band clamps and 30-35 ft-lbs for U-bolt clamps. Over tightening will result in the clamp breaking and will NOT be warranted by MagnaFlow.



Step 1. To extract the OEM exhaust system it is necessary to remove the underbody braces on the rear of the vehicle. Begin removing the exhaust by un-fastening the front clamps located behind the catalytic converters. Next, with the exhaust supported, work rearward and disengage all welded hangers from the rubber insulators. Do not damage or discard the rubber insulators or clamps as they will be re-used to mount the new system. You can now remove the exhaust from the vehicle.

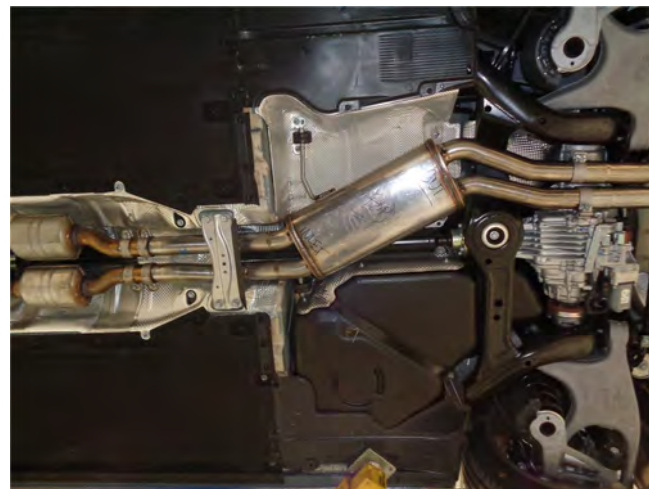

Step 2. Begin installation of the new system by fastening the Resonator Assembly inlet to the catalytic converter using the OEM clamps and fitting the hangers into the rubber insulators (Leave all clamps and fasteners loose for final adjustment of the complete system.)



Step 3. Next, install the Mid Pipes to the Resonator Assembly using the supplied 2.25" clamps. Finish by attaching the Muffler Assemblies to the Mid Pipes using the supplied 2.25" clamps. Insert hangers into rubber insulators.



Step 4. Once a final position has been chosen for the new exhaust system, evenly tighten all clamps from front to rear using the torque specifications on page one of the instructions. Inspect all fasteners after 25-50 miles of operation and re-tighten if necessary.