

2007-2015 JEEP WRANGLER 3.6L/ 3.8L BLACK

Warning When working on, under, or around any vehicle exercise caution. Please allow the vehicle's exhaust system to cool before removal, as exhaust system temperatures may cause severe burns. If working without a lift, always consult vehicle manual for correct lifting specifications. Always wear safety glasses and ensure a safe work area. Serious injury or death could occur if safety measures are not followed.

Step 1: (Carefully read all instructions before installation) Remove the OEM Muffler Assembly by loosening the clamp located at the pipe junction near the rear axle and extract the hangers from the rubber insulators. Be careful not to damage the OEM rubber insulators as they will be re-used to mount the new system.

Step 2: Using the Supplied 2.50" clamp install the new Muffler Assembly by sliding the inlet pipe onto the outlet of the factory system and fitting the welded hangers into the OEM rubber insulators.

Step 3: With all components mounted loosely, adjust the system for overall aesthetics and clearance of frame & bodywork. (MAGNAFLOW recommends at least 1/2" of clearance between the exhaust system and any body panels to prevent heat-related body damage or fire.)

Step 4: Once a final position has been chosen for the new system, evenly tighten all fasteners from front to rear. The supplied band clamps must be VERY tight to properly align the pipes and prevent leaks (Approximately 40ft-lbs). Inspect all fasteners after 25-50 miles of operation and retighten if necessary.

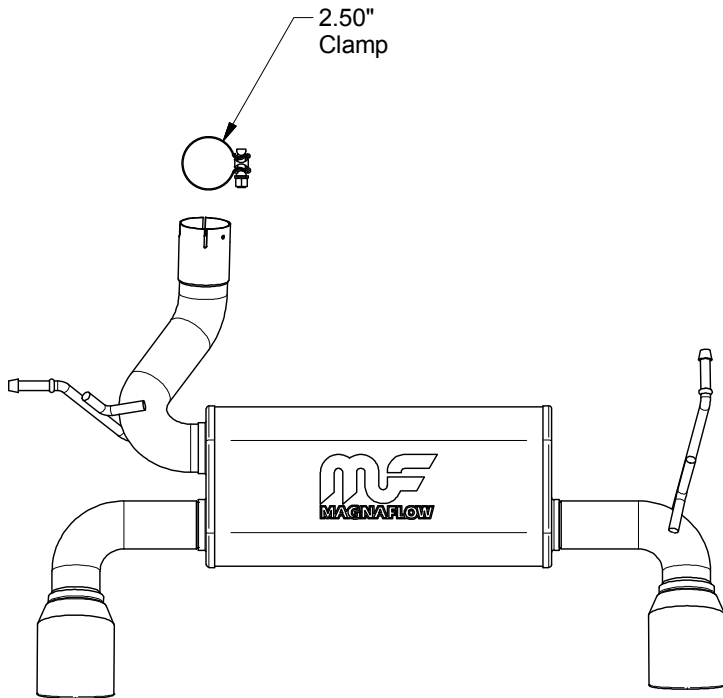

**** Magnaflow Performance Exhaust recommends professional installation on all their products**